

Science and Technology Create Perfection

Installation and Operating Manual

SR881 SOLAR STATION

For Split Pressurized Hot Water System



⚠ Read the instruction carefully please before operation!

Contents

Solar pump station installation and operation manual	4
1. Solar pump station with integrated controller	4
1.1 Scope of delivery	4
1.2 About this manual	4
1.3 Safety instructions	4
1.4 Station dimensions:	5
1.5 Specification of components	5
1.6 Technical Data:	6
2. Mounting station	6
3. Commissioning of station	7
3.1 Flushing and filling the solar system	7
3.2 Flow check	8
3.3 Electrical connection	8
3.4 Accessories for the station(A06)	9
Manual of integrated controller of solar station	10
1. Safety information	10
1.1 Important remark	10
1.2 Description of symbols	10
1.3 Description of operation button	10
1.4 Terminal layout	11
2. Commissioning of integrated controller	13
2.1 Set time/week	13
2.2 Menu structure	14
2.3 Menu description	15
2.4 System description	16
3. Timing heating	17
4. Controller functions	20
4.1 Access main menu	20
4.2 Access submenu	20
4.3 Main menu DT O & DT F Temperature difference function	21
4.4 Main menu - TEMP Temperature	22
4.4.1 EMOF maximum switch-off temperature of collector (Collector Emergency Shut	

Down Function)	22
4.4.2 EMON maximum switch-on temperature of collector (Collector Emergency Shut Down Function)	23
4.4.3 CMX Maximum limited collector temperature (collector cooling function)	23
4.4.4 CMN low temperature protection of collector.....	24
4.4.5 CFR frost protection of collector.....	25
4.4.6 SMX Maximum temperature of tank.....	26
4.4.7 REC Tank re-cooling function	26
4.4.8 C- F Celsius and Fahrenheit temperature switch.....	27
4.5 Main menu - FUN Auxiliary function.....	27
4.5.1 DVWG Anti-Legionella function	28
4.5.2 nMIN Solar circuit pump speed adjusting (RPM speed controlling)	29
4.5.2.1 DTS Standard temperature difference (for circuit pump's speed adjusting) ...	29
4.5.2.2 RIS Temperature increase rate (for circuit pump speed adjusting).....	30
4.5.3 OHQM Thermal energy measuring.....	30
4.5.3.1 FMAX Flow rate	31
4.5.3.2 MEDT Type of heat transfer liquid	32
4.5.3.3 MED% Concentration of heat transfer liquid.....	32
4.5.4 FTYP Type of Flow meter (optional).....	33
4.5.5 INTV Pump interval function	33
4.5.5.1 tSTP Pump interval- time	34
4.5.5.2 tRUN Pump running time	34
4.6 HND Manual mode.....	34
4.7 PASS Password setting.....	35
4.8 LOAD Recovery factory setting.....	36
4.9 On/OFF button	36
4.10 Holiday function	36
4.11 Manual heating	37
4.12 Temperature check	38
5. Protection function.....	39
5.1. Memory protection	39
5.2 Screen protection	39
6. Trouble shooting	39
6.1 Trouble protection.....	39

Solar station manual

6.2 Trouble checking	39
7. Quality Guarantee	41
8. Technical data.....	41
9. Accessories to this controller	42

Solar pump station installation and operation manual

1. Solar pump station with integrated controller

- Integrated solar controller
- outstanding design
- Safety assembly with safety valve and manometer
- High-Quality casing for reduce heat losses
- Flow rate check



1.1 Scope of delivery

- 1* solar pump station
- 1* integrated solar controller
- 1* flushing and filling unit (option)
- 1* collector sensor PT1000
- 2* store sensor NTC10K
- 1* wall mounting bracket
- 1* accessory bag (include 2 * screw and dowel ; 2 * strain relief)
- 1* manual

1.2 About this manual

This solar pump station is a preinstalled and leak-tested group of fitting for transferring heat from the collector to the store. It contains important fittings and safety devices for the operation of the solar thermal system:

- Ball valves in flow and return in combination with check valves to prevent gravity circulation.
- Flow rate check for displaying the flow rate
- Manometer for displaying the system pressure
- Safety valve to prevent inadmissible overpressure
- Flushing and filling unit (optional) for flushing, filling and emptying the solar thermal system.

1.3 Safety instructions

The installation and commissioning of the solar station as well as the connection of electrical components requires technical knowledge commensurate with a recognized vocational qualification as a fitter for plumbing, heating and air conditioning technology, or a profession requiring a comparable level of knowledge. The following must be observed

during installation and commissioning:

- The relevant regional and national regulations.
- The technical and safety instructions of these instructions.

Warning: risk of scalding

There is danger of steam emission with safety valves. Therefore a discharge pipe must be connected to the safety assembly.

Attention: damage of solar pump station

- The group of fittings must be installed with sufficient spacing to the collectors because temperatures in the vicinity of the collectors can be very high. An intermediate vessel may be necessary for installation in the attic.
- It is imperative that you make sure the **PTFE** sealing elements of the solar pump station do not come into contact with substances containing mineral oil. Mineral oil products cause lasting damage to the material, whereby its sealant properties are lost. If necessary, ask the manufacturer whether the solar fluid, fats or installation aids contain mineral oils.
- We don't assume liability nor provide warranty for damage to solar station resulting from sealants damaged in this way.

1.4 Station dimensions:

Height (with insulation): 400mm

Width (with insulation): 200mm

Depth (with insulation): 145mm

Distance centre: 1600mm

Distance axis/wall: 55mm

Pipe connections: 3/4" IT

Connection for expansion vessel set: 3/4"ET, flat sealing

Outlet safety valve: 1/2 IT



1.5 Specification of components

1.5.1 Safety valve: 6bar

1.5.2 Manometer: 0-6bar

1.5.3 Non-return valve: opening pressure 200mmH₂O

1.5.4 Circuit pump: Wilo 15-6

1.5.5 Digital flow counter (alternative Mechanical flow counter)

1.5.6 Return outlet connection (from collector):

3/4 IT

1.5.7 wiring terminal of controller

1.5.8 EPP insulation case

1.5.9 Flow outlet connection (to collector):3/4'

IT

Material:

Fitting: brass

Seals: PTFE

Insulation: EPP, $\lambda= 0.041W/ (m.K)$

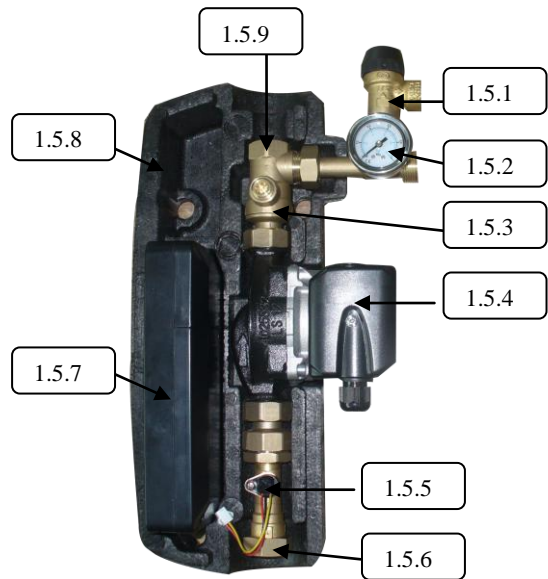

1.6 Technical Data:

Max. permitted pressure: 6bar

Max. permitted operating temperature: 120 °C

Digital flow rate: 1-20L/Min

Mechanical flow rate: 2-8L/Min

2. Mounting station

- Determine the mounting site of the station.
- Take the station out of packing; Remove the front half of the insulation.
- Hold the enclosed wall mounting bracket against the wall and mark the fastening holes, drill holes and insert dowels.
- Fasten the wall mounting bracket to the wall with the screws.
- Push the station against the wall mounting bracket, the station catches and is then attached to the wall.
- Connect the station to the solar thermal system.
- Check the inlet pressure of the expansion vessel and if necessary, adjust it to the local conditions, $P_{inlet}(\text{bar}) = 1\text{bar} + \Delta Th(\text{m}) * 1/10$ (ΔTh =height difference between collector and station) .
- Connect the electrical components of the solar station, Attach the store and collector sensor and connect there to the controller, plug the controller into the socket.
- Tighten all union nuts and screw connections.

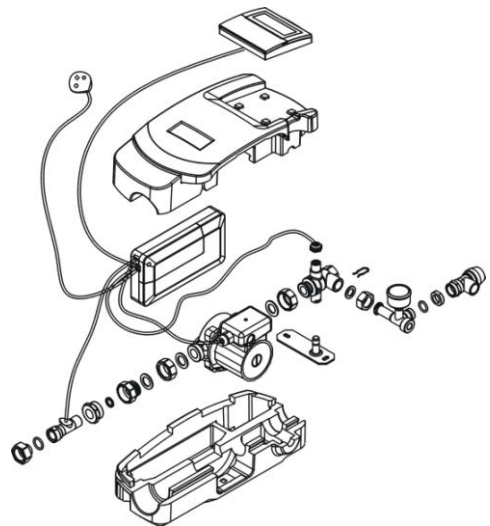

- Attach the front half of the insulation to the station.

3. Commissioning of station

Attention: Risk of scalding!

In order to prevent the boiling of solar fluid in the collectors, the system should not be flushed or filled during periods of strong sunshine.

Attention: Risk of frost!

Solar thermal system cannot be completely emptied after flushing. There is a danger of frost damage if water is used for flushing. Only use solar fluid to flush and fill the solar thermal system. Use water –propylene glycol mixture as solar fluid (Maximum 50% propylene glycol).

3.1 Flushing and filling the solar system

Flushing and filling unit is optional component, it can be installed horizontally at the lowest point of the solar circuit (see figure). A filter must be installed between the store and solar pump in order to prevent the flushed-out scale from store re-entering the solar circuit.

Flushing and filling steps:

- Disconnect the expansion vessel from the solar thermal system.
- Connect the pressure hose of a flushing and filling station to the fill ball valve (1) of flushing and filling unit.
- Connect the flushing hose of a flushing and filling station to the drain ball valve (3) of flushing and filling unit.
- Close the ball valve (2) in the centre of the flushing and filling unit.
- Open the filling ball valve (1) and drain ball valve (3).
- Flush the solar thermal system using the flushing and filling station for at least 15minutes to remove all air from the system.
- During the flushing, bleed the solar thermal system several times at the airstopp until the discharged solar fluid is free of air bubbles.

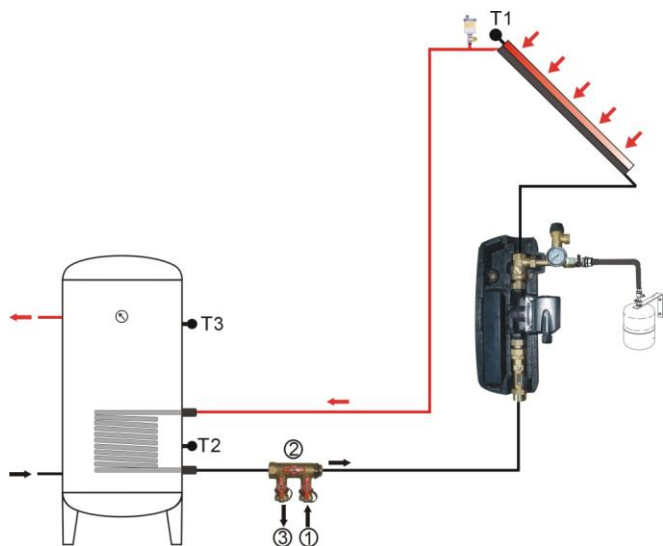

Solar station manual

- Close the drain ball valve(3) of flushing and filling unit, and continues run the pump and increase the system pressure to approx.5 bar, system pressure can be read from the manometer.
- Close the filling ball valve (1) of the flushing and filling unit, and then close the filling pump.
- Check the manometer to see whether the system pressure reduces and eliminate leaks where necessary.
- Reconnect the expansion vessel to the solar thermal system.

3.2 Flow check

The flow counter is used for measurement and display of flow rate, in order to guarantee the flawless function of the measuring device the system must be flushed and free from foreign substances.



Digital flow meter (1-20L/min)

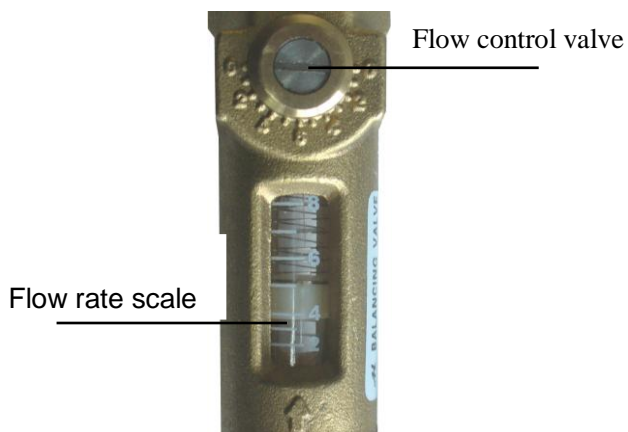

Mechanical flow meter (2-8L/min)

3.3 Electrical connection

Warning: disconnect the controller from power supply before opening the housing!

The controller is already integrated in the station and ready to plug in, display and digital counter are already preinstalled at factory. For maintenance or service work, it needs to take out the controller from station, doing follows below steps:

- Switch off the system, disconnect plug from the mains.

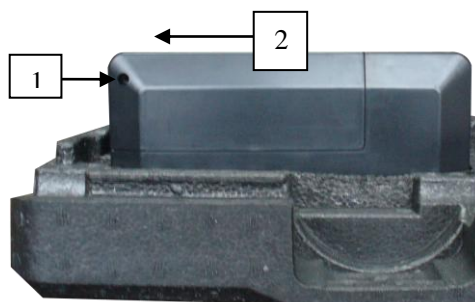

Solar station manual

- Remove the front half of the insulation.
- Unscrew the cross-recessed screw 1 of the front cover of controller and left moving out the cover 2.
- Disconnect the wires from controller, take out the controller.
- Doing reverse steps to remount the controller.

For further information on electrical connection of the controller, please see manual of controller (terminal layout).

3.4 Accessories for the station(A06)

Flushing and filling unit isn't enclosed in the delivery scope. Please buy separately.



(A06)

Manual of integrated controller of solar station

1. Safety information

1.1 Important remark

We have carefully checked the text and figures of this manual and provided the best of our knowledge and ideas, however inevitable errors maybe exist. Please note that we cannot guarantee that this manual is given in the integrity of image and text, they are just some examples, and they apply only to our own system. Incorrect, incomplete and erroneous information and the resulting damage we do not take responsibility.

1.2 Description of symbols



Safety instruction:

The safety instructions in the manual are marked with a warning triangle. They indicate measures, which can lead to personal injury and safety risks.

Operation steps: small triangle “▶” is used to indicate operation step.

Notes: Contains important information about operation or function.

1.3 Description of operation button

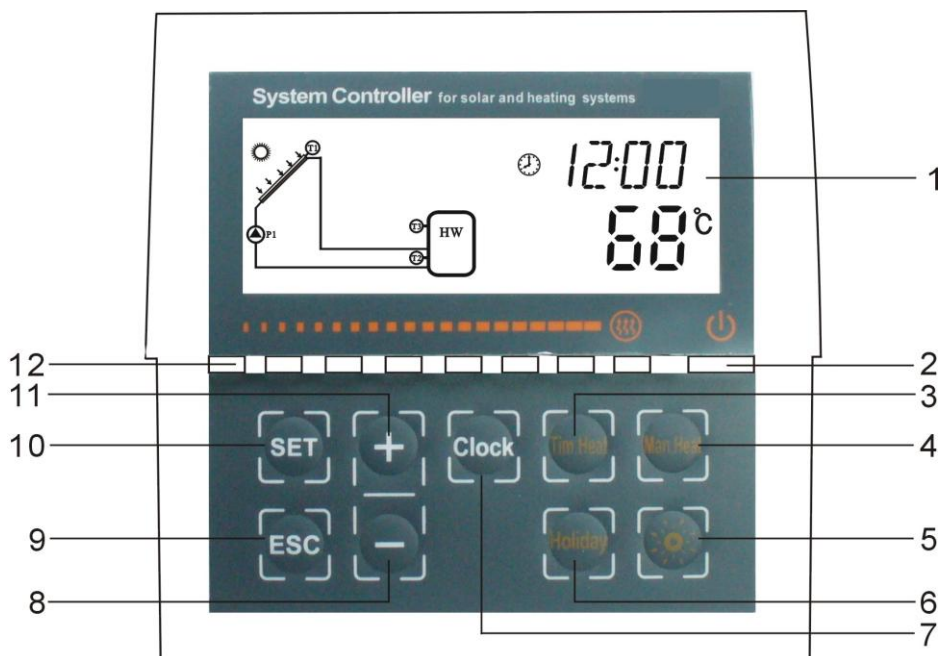

No.	Button description	Function
1	LCD Display	
2	“Off/on” button	Switch on/off power of controller
3	“Tim. Heat” button	Switch on/off the timing heating function
4	“Man. Heat” button	Manual switch on/off the heating function
5	“LED on/ off” button	Switch on/off LED power
6	“Holiday” button	Activate/deactivate holiday function
7	“Clock” button	Clock function
8	“-” Parameter adjust button	Parameter adjust, value decrease
9	“ESC” button	Exit program setup
10	“SET” button	Confirm setting
11	“+” Parameter adjust button	Parameter adjust, value increase
12	LED indicating light	

● **LED indicating light**

LED indicating light displays the temperature of store. The first LED indicating light is on, it means the temperature of store is 10°C, the second light is on, it means store temperature is 20 °C, others is same. See figure:

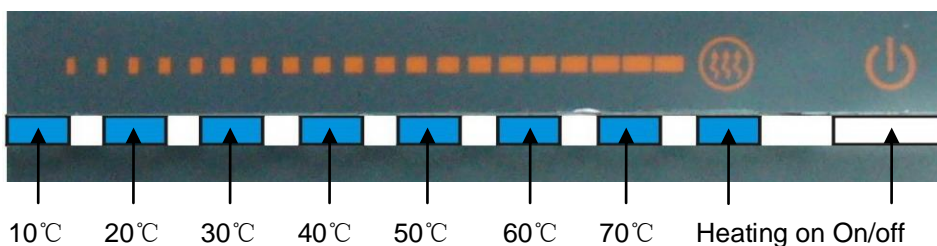

1.4 Terminal layout

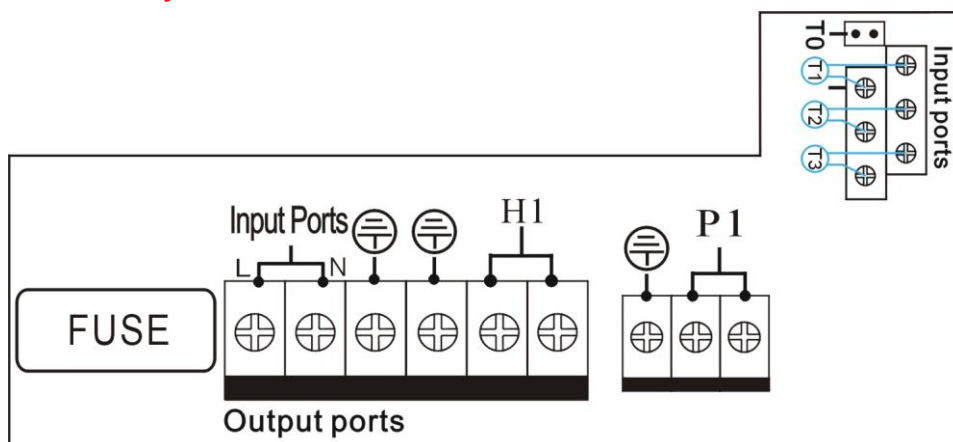

- **Power terminal : L, N,GND**

Input ports L, N is power connection terminal, please connect correctly.



is Ground line terminal.

- **Sensor input ports**

Input sensor ports T0: for NTC10K, B=3950 sensors, used for measuring the temperature of collector and measuring the heat output.

Input sensor ports T1: for Pt1000 sensors, used for measuring the temperature of collector and measuring the heat output.

Input sensor ports T2, T3: for NTC10K, B=3950 sensors, used for measuring the temperature of tank.

- **Advice regarding the installation of temperature sensors:**

Only original factory enclosed Pt1000 temperature sensors are approved for use with the collector, it is equipped with 1.5meter silicon cable and suitable for all weather conditions, the temperature sensor and cable are temperature resistant up to 280^oC, not necessary to distinguish the positive and negative polarity of the sensor connection.

Only original factory enclosed NTC10K,B=3950 temperature sensors are approved for use with tank and pipe, it is equipped with 1.5meter PVC cable, and they are temperature resistant up to 105^oC, not necessary to distinguish the positive and negative polarity of the sensor connection.

All sensor cables carry low voltage, and to avoid inductive effects, must not be laid close to 230 volt or 400-volt cables (minimum separation of 100mm)

If external inductive effects are existed, e.g. from heavy current cables, overhead train cables, transformer substations, radio and television devices, amateur radio stations, microwave devices etc, then the cables to the sensors must be adequately shielded.

Sensor cables may be extended to a maximum length of ca. 100 meter, when cable's length is up to 50m, and then 0.75mm² cable should be used. When cable's length is up to 100m, and then 1.5mm² cable should be used.

● **Output ports**

Output P1: For solar circuit pump and also suitable for RMP control, Semiconductor relay (SCR relay), Max. Switching current 1A,

Output H1: For back-up electrical heater, electromagnetic relay, and max. Switching current 10A, H1 connection ports are always open.

2. Commissioning of integrated controller



Connect the sensors, pumps or switching valves to the controller before you connect the power supply! After switching on power to the controller, firstly it will ask for to set the time, password and parameters of system.

2.1 Set time/week

▶ Press “Clock” button, time displays on screen, our selection area “00” blinks on display screen.

▶ Press “+”“-” button to set hour of clock

▶ Press “Clock” button again, minute area “00” blinks

▶ Press “+”“-” button to set minute of clock.

▶ Press “Clock” again, week area “MO” blinks

▶ Press “+”“-” button to set week.

▶ Press “ESC” button to exit set program, or wait for 20 seconds to exit program automatically.

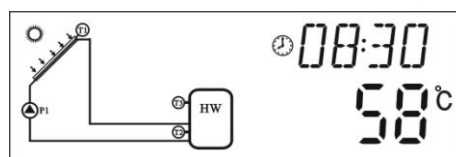

Code	Weekday
MO	Monday
TU	Tuesday
WE	Wednesday
TH	Thursday
FR	Friday
SA	Saturday
SU	Sunday

2.2 Menu structure

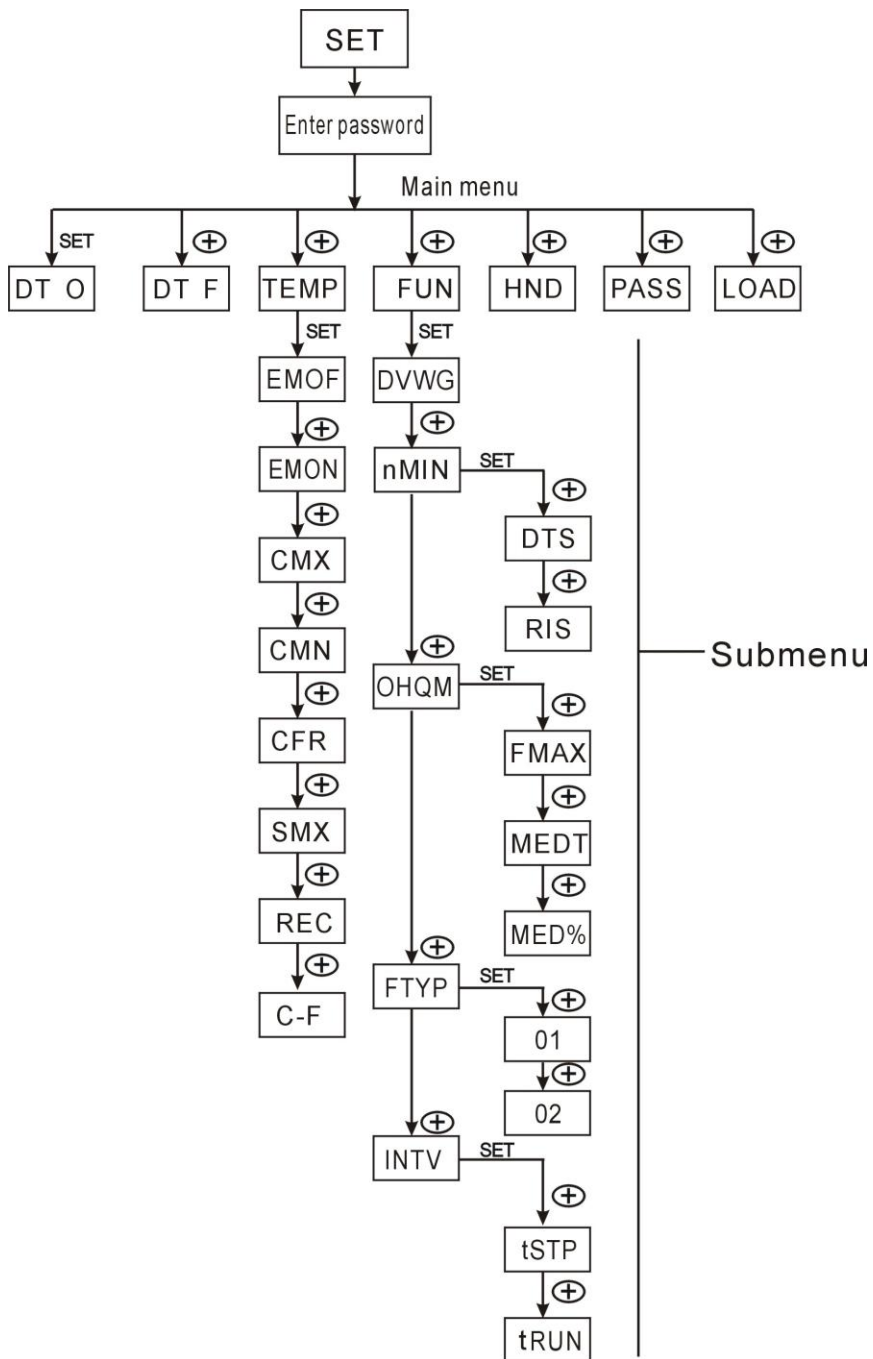

Submenu:

Through submenu, user can set the parameter as desired value, please check it carefully.

2.3 Menu description

Code (Main menu)	Code (Submenu)	Code (Submenu)	Menu Description	Remark
DT O			Switch-on temperature difference	
DT F			Switch-off temperature difference	
TEMP			Temperature	
	EM		Limited temperature of collector (Emergency turnoff temperature of collector)	
		EMOF	The maximum switch-off temperature of collector	
		EMON	The maximum switch-on temperature of collector	
	CMX		Maximum temperature of collector (Collector cooling function)	
	CMN		Low temperature protection of collector	
	CFR		Frost protection of collector	
	SMX		Maximum temperature of tank	
	REC		Tank re-cooling function	
	C-F		Celsius and Fahrenheit temperature switch	
FUN			Auxiliary function	
	DVWG		Anti legionnaires' function	
	nMIN		Speed controlling of circulation pump (RPM pump controlling)	
		DTS	Standard temperature difference (for circulation pump speed adjust)	
		RIS	Increase scale (circulation pump speed adjusting parameter set)	
	OHQM		Thermal energy measuring	
		FMAX	Flow rate	When use digital flow counter, no value displays on screen
		MEDT	Type of heat transfer liquid	
		MED%	Concentration of heat transfer liquid	
	FTYP		Type of Flow meter	
		01	mechanical flow meter	
		02	digital flow meter	
	INTV		Pump interval function	
		tSTP	Pump interval time	
		tRUN	Pump running time	
HDN			Manual controlling	
PASS			Password set	
LOAD			Recovery to factory set	

2.4 System description

Note:

T3 is alternative sensor, when no sensor (T3) is installed on the top part of tank, controller will use the signal of sensor T2 automatically to control the auxiliary heating or the circulation pump.

1 collector array – 1 storage tank – 1 pump and auxiliary heating

Description:

The solar circuit pump (P1) is switched on as soon as the switch-on temperature difference (ΔT_{on}) between the collector array (T1) and the storage tank (T2) is reached. If the temperature difference between the collector array (T1) and storage tank (T2) drops below the switch-off temperature difference (ΔT_{off}), or the temperature of storage tank (T3) reaches the preset maximum storage temperature, then the solar circuit pump (P1) is switched off.

Back-up heating by auxiliary boiler (detailed see paragraph 4.3):

Within the preset schedule of back-up heating, if the temperature T3 is below the switch-on temperature, then the back-up heating (H1) is triggered, when T3 is heated to the switch-off temperature, back-up heating H1 is ceased.

T0: Temperature sensor for thermal energy measuring (optional sensor)

T1: Temperature sensor for collector array

T2: Temperature sensor on the bottom part of tank 1.

T3: Temperature sensor on the top part of tank (optional sensor)

P1: Solar circuit pump

H1: output for back-up electrical heater

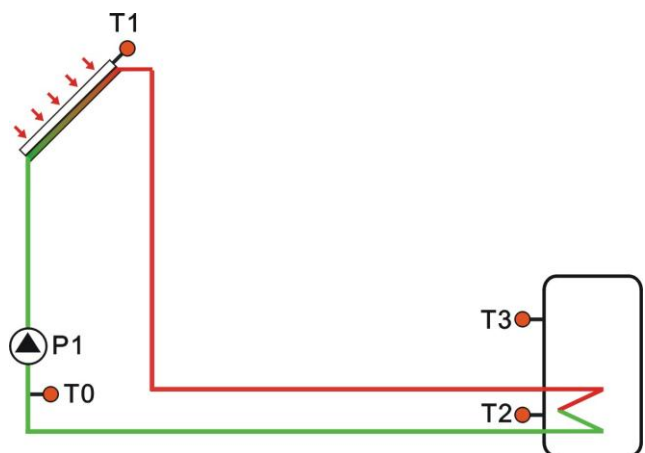

3. Timing heating

Description:

Electrical heater, gas boiler or oil boiler can be integrated into solar system used as back-up of system, and they can be triggered automatically at preset schedule by preset temperature. Within a preset schedule, when the temperature (T3) of top part of tank drops below the preset switching-on temperature of this function, back-up heating starts to work, when T3 rises up to the preset turning off temperature, back-up heating is stopped. Within 24 hours, three time sections can be set with this controller.

Factory set:

The first schedule: back-up heating function starts at 4:00 and ends at 5:00 am. Within this time section, switch-on temperature is 40°C; switch-off temperature is 45°C.

The second schedule: from 10:00 to 10:00 am, it means there is no back-up heating in this time.

The third schedule: back-up heating function starts at 17:00 and ends at 22:00 pm. Within this time section, the switch-on temperature is 50°C; switch-off temperature is 55°C.

The switch-on temperature adjustable range: 10 °C ~ (OFF-2 °C)

The switch-off temperature adjustable range: (ON+2 °C) ~ 80 °C

If you want to shut off one timing heating, then you can set the turning on time and turning off time same value (for example, the second time section no this function, then you can set turning on/off time is 10:00 ~ 10:00)

When time is outside of the preset schedule, back-up heating doesn't work automatically even when the tank temperature reaches the switch –on temperature of heating.

Note:

- When there is no sensor installed in the top part of tank (no T3 sensor), controller will take the signal of T2 (sensor in bottom of tank) automatically to control this function.
- The time in this controlled is 24 hours, when you set schedule, the switch-off time of heating should be larger than switch-on time. For example: if you set the switch-on time of heating is at 17:00, but switch-off time of heating is 6:00, then this setting doesn't take effect, that means within this time section, heating function doesn't work. The correct set is like flowing: it should be divided into two time sections, one time section is from 17:00 to 23:59, the other time section is from 00:00 to 06:00.

Setup steps:

▶ Press button “Tim. Heat” to access THET program to set parameter, “tH 1o 04:00” displays on screen, the switch-on time and temperature for the first schedule of heating function can be set.



- ▶ Press “SET” button, “04” of hour time blinks on screen
- ▶ Press “+”“-” button to adjust hour of time
- ▶ Re-press “SET” button again, “00” of minute time blinks on screen
- ▶ Press “+”“-” button to adjust minute of time
- ▶ Re-press “SET” button, temperature “40 °C” blinks on screen
- ▶ Press “+”“-” button, to set the switch-on temperature of heating
- ▶ Then, Press “ESC” to exit this set

▶ Re-press button “Tim. Heat”, “tH 1F 05:00” displays on screen, the switch-off time and temperature for the first schedule of heating function can be set.

▶ Press “SET” button, “05” of hour time blinks on screen.

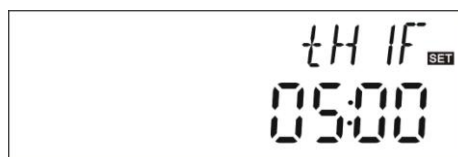

- ▶ Press “+”“-” button to adjust hour of time
- ▶ Re-press “SET” button, “00” of minute time blinks on screen
- ▶ Press “+”“-” button to set minute of time
- ▶ Re-press “SET” button, temperature “45 °C” blinks on screen
- ▶ Press “+”“-” button, to set switch-off temperature of heating
- ▶ Press “ESC” to exit this set program, parameters are saved automatically

▶ Re-press button “Tim. Heat”, “tH 2o 10:00” displays on screen, the switch-off time and temperature for the second schedule of heating function can be set.

▶ Press “SET” button, “10” of hour time blinks on screen.

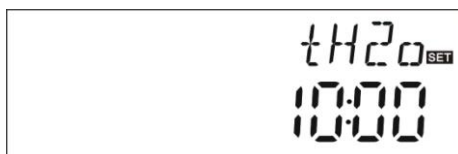

- ▶ Press “+”“-” button to adjust hour of time
- ▶ Re-press “SET” button, “00” of minute time blinks on screen
- ▶ Press “+”“-” button to set minute of time
- ▶ Re-press “SET” button, temperature “50 °C” blinks on screen

- ▶ Press “+”“-” button, to set switch-off temperature of heating
- ▶ Press “ESC” to exit this set program, parameters are saved automatically

▶ Repress button “Tim. Heat”, “tH 2F 10:00” displays on screen, the switch-off time and temperature for the second schedule of heating function can be set.

▶ Press “SET” button, “10” of hour time blinks on screen.

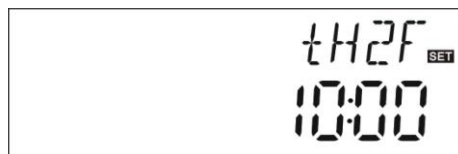

▶ Press “+”“-” button to adjust hour of time

▶ Reprress “SET” button, “00” of minute time blinks on screen

▶ Press “+”“-” button to set minute of time

▶ Reprress “SET” button, temperature “55°C” blinks on screen

▶ Press “+”“-” button, to set switch-off temperature of heating

▶ Press “ESC” to exit this set program, parameters are saved automatically

▶ Reprress button “Tim. Heat”, “tH 3o 17:00” displays on screen, the switch-off time and temperature for the third schedule of heating function can be set.

▶ Press “SET” button, “17” of hour time blinks on screen.

▶ Press “+”“-” button to adjust hour of time

▶ Reprress “SET” button, “00” of minute time blinks on screen

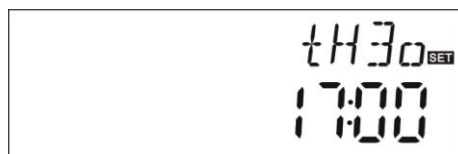

▶ Press “+”“-” button to set minute of time

▶ Reprress “SET” button, temperature “50°C” blinks on screen

▶ Press “+”“-” button, to set switch-off temperature of heating

▶ Press “ESC” to exit this set program, parameters are saved automatically

▶ Reprress button “Tim. Heat”, “tH 3F 22:00” displays on screen, the switch-off time and temperature for the third schedule of heating function can be set.

▶ Press “SET” button, “22” of hour time blinks on screen.

▶ Press “+”“-” button to adjust hour of time

▶ Reprress “SET” button, “00” of minute time blinks on screen

▶ Press “+”“-” button to set minute of time

▶ Reprress “SET” button, temperature “55°C” blinks on screen

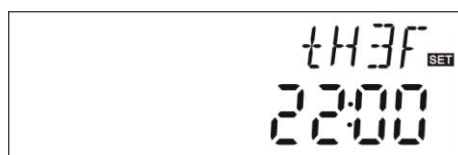

▶ Press “+”“-” button, to set switch-off temperature

of heating

▶ Press “ESC” to exit this set program, or wait for 20 seconds to exit automatically, the setup parameters are saved automatically.

Note: when no gas or oil boiler is connected to solar system, electrical heater can be installed as back-up device, when electrical heater is in operation status, signal  blinks on screen, and LED light is on.

If customer use electrical heater as back-up, please according to the power of electrical heater to equip corresponding safety devices like contactor and breaker with this controller, we strongly recommend equipping with SR802 device with this controller, (SR802 detailed technical data see paragraph 9 spare parts)

4. Controller functions

4.1 Access main menu

Under standby status, doing like following access main menu

▶ Press “SET” button, “PWD 0000” displays on screen, the left first digital blinks, ask for entering password, factory default password is “0000”

▶ Press “+”“-” button to enter first digital of password.

▶ Press “SET” button again, the second digital blinks

▶ Press “+”“-” button, to enter second digital of password

▶ Press “SET” button again, the third digital blinks

▶ Press “+”“-” button to enter the third digital of password

▶ Press “SET” button again, the fourth digital blinks

▶ Press “+”“-” button, to enter the fourth digital of password

▶ Press “SET” button again to access main menu

▶ Press “+”“-” button, can select the main menu

▶ Press “ESC” button to exit main menu

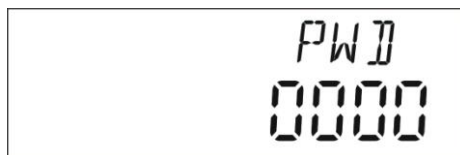

4.2 Access submenu

After selecting main menu, do like following access submenu

▶ Press “SET” button, to access submenu

▶ Press “+”“-” button to select submenu

- ▶ Press “SET” button again to access program, can adjust parameter value now
- ▶ Press “+”“-” button, to adjust the value of parameter
- ▶ Press “ESC” button, exit program of submenu
- ▶ Press “ESC” button again, to exit main menu.

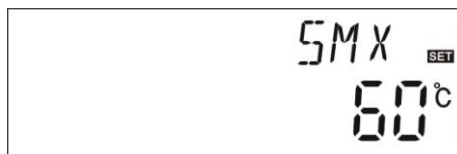

For example: submenu

4.3 Main menu DT O & DT F Temperature difference function

Description:

Solar circuit pump P1 is triggered by the temperature difference function, so long as the temperature difference between collector and tank reaches the switch-on DT, solar circuit pump is triggered.

For example: the switch-on DT is 8 °C, switch-off DT is 4 °C, if the temperature in the bottom part of tank is 20 °C, then just when collector temperature rises up to 28 °C, pump is triggered, and when collector temperature drops to 24 °C, pump is ceased.

Note: the switch-on/off DT of 8 °C and 4 °C are standard system setting according to many years' experience, only in special application cases it needs to be changed, (e.g. far distance heat transferring), normally it is recommend using default set. Switch-on and switch-off DT are alternating set. To avoid mistake the minimum difference between two temperature differences ($\Delta T_{on} - \Delta T_{off}$) is set as 2°C.

Setup the switch-on temperature difference:

Under standby status, access main menu DT O,

- ▶ Press “SET” button, to access settings program of DT O, “DT O 08 °C” displays on screen, “08 °C” blinks, the switch-on temperature difference can be set.
- ▶ Press “+”“-” button, to adjust the value of switch-on DT, adjustable range (OFF+2 °C) ~ 20 °C, factory setting is 8 °C
- ▶ Press “ESC” button to exit this setting, parameter is saved automatically.

Setup the switch-off temperature difference:

Under standby status, access main menu DT F

- ▶ Press “SET” button, to access settings program of DT F, “DT F 04 °C” displays on screen, “04 °C” blinks, the switch-off temperature difference can be set.
- ▶ Press “+”“-” button to adjust the value of switch-off DT, adjustable range 0 °C ~ (ON-2 °C), factory set is 4 °C.

► Press “ESC” to exit menu, or wait for 20 seconds to exit automatically, the setup parameters are saved automatically.

4.4 Main menu - TEMP Temperature

For every system, the factory set parameters are in the best condition that is fully integrated into the entire solar system. But these parameters can also be set individually to cater the special requirements, please carefully observe the operation data of system components after setting.

Note: parameters that can be set depend on the selected system, not all the parameters can be adjusted in a solar system.

Following submenus and parameters can be set under TEMP main menu.

Sub menu	Function description	Adjustable range	Factory set	Function exit temperature	Paragraph
EMOF	The maximum switch-off temperature of collector	(ON+3°C) ~200°C	130°C		See 4.4.1
EMON	The maximum switch-on temperature of collector	60°C ~ (OFF-3°C)	120°C		See 4.4.2
CMX	Maximum limited collector temperature (collector cooling function)	60°C~190°C	110°C	107°C	See 4.4.3
CMN	Low temperature protection of collector	0°C~90°C	OFF		See 4.4.4
CFR	Frost protection of collector	-10°C~10°C	OFF		See 4.4.5
SMX	Maximum temperature of tank	2°C~95°C	70°C	68°C	See 4.4.6
REC	Tank re-cooling function		OFF		See 4.4.7
C-F	Celsius and Fahrenheit temperature switch	°C~°F	°C		See 4.4.8

4.4.1 EMOF maximum switch-off temperature of collector (Collector Emergency Shut Down Function)

Function description:

When collector temperature rises up to the maximum switch-off temperature of collector (EMOF), this function is activated, solar circulation pump is stopped in order to avoid the damage of system other components caused by high temperature. The adjustable range of this EMOF temperature is (ON+3°C) ~200°C, factory set is 130°C. When the temperature of collector rises up to EMOF temperature, solar circuit pump is locked, but when collector

temperature drops to the maximum switch-on temperature of collector (EMON)(factory set is 120°C), solar circuit pump is unlocked, and this function is deactivated.

Select EMOF submenu, “EMOF 130°C” displays

▶ Press “SET” button, 130°C blinks.

▶ Press “+”“-” button, adjust the EMOF temperature, adjustable range: (ON+3°C) ~ 200°C ,factory set is 130°C

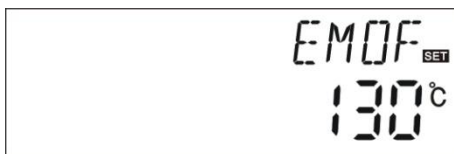

▶ Press “SET” button, activate and deactivate this

function, if the function is deactivated, then “EMOF ----“displays on the screen.

▶ Press “ESC” button to exit menu or wait for 20 seconds to exit automatically, set parameters are saved automatically.

4.4.2 EMON maximum switch-on temperature of collector (Collector Emergency Shut Down Function)

Select EMON submenu, “EMON 120°C” displays

▶ Press “SET” button, 120°C blinks.

▶ Press “+”“-” button, adjust the EMON temperature, adjustable range: (OF-3°C) ~200°C , factory set is 120°C.



▶ Press “SET” button, activate and deactivate this function, if the function is deactivated, then “EMON ----“displays on the screen.

▶ Press “ESC” button to exit menu or wait for 20 seconds to exit automatically, set parameters are saved automatically.



When these two signals of EM blink on the screen, it indicates this function is activated, and at this moment temperature of tank reaches to its maximum limited temperature



When only this signal of EM blinks on the screen, it indicates this function is also activated, but temperature of tank doesn't reach to its maximum limited temperature

4.4.3 CMX Maximum limited collector temperature (collector cooling function)

Function description:

The collector cooling function delays the vaporization of the heat transfer fluid. Shortly

before reaching the maximum temperature of the collector, the solar pump starts working to cool down the heat transfer fluid by the heat losses occurring in pipelines and storage cylinder.

When tank temperature rises to its preset maximal temperature, solar circuit pump is ceased compulsively even the temperature difference is satisfied. If the sunshine is very good, as a result collector temperature will rise continuously, when collector temperature rises up to its maximal temperature, solar pump will be triggered again even at the case that tank temperature is already to its maximal temperature. And solar pump works until the temperature of collector is decreased by this reversed circulation or when tank temperature rises its emergency temperature (95°C).

When ☀ displays, and Ⓢ blinks on the screen, it indicates that tank emergency temperature reaches, tank temperature is $\geq 95^{\circ}\text{C}$

Setup steps:

To access main menu TEMP, then select submenu CMX “CMX 110°C” displays on the screen.

▶ Press “SET” button, parameter “110°C” blinks.

▶ Press “+”“-” button, to adjust the collector protection temperature, adjustable range ($60^{\circ}\text{C} \sim 190^{\circ}\text{C}$), factory set is 110°C

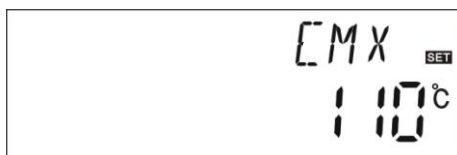

▶ Repress “SET” button, activate and deactivate this function, if deactivate the function, “CMX - - -” displays on screen.

▶ Press “ESC” button to exit the menu or wait for 20 seconds to exit automatically, parameters are saved automatically.

☀ CMX signal displays on screen, it indicates that this function is in activated.

4.4.4 CMN low temperature protection of collector

Description:

When the temperature of collector is below preset CMN temperatures, solar circuit pump is locked, even when the temperature difference between collector and tank exceeds switch-on temperature difference, solar pump doesn't work yet. When temperature of collector is 3°C higher that the preset CMN temperature, solar circuit pump is unlocked for operating, controller exits this program.

Setup steps:

To access main menu TEMP, then select submenu CMN, “CMN-----” displays on screen, default set is off.



- ▶ Press “SET” button, default off signal “- - -” blinks on screen.
- ▶ Repress “SET” button, to activate and deactivate this function
- ▶ Press “+”“-” button, to adjust the low protection temperature of collector CMN, adjustable range (00°C~90°C), after activate the function, factory set is 10°C
- ▶ Press “ESC” button to exit the menu or wait for 20 seconds to exit automatically, parameters are saved automatically.



CMN signal displays on screen, it indicates that this function is in activated.

4.4.5 CFR frost protection of collector

Description:

In winter when the temperature of collector is below the preset frost protection temperature (factory set is 4 °C), Solar circuit pump is triggered to circuit solar liquid reversed. Besides when tank temperature (T2) drops to 6°C, electrical heater is triggered automatically and it is in operation until T2 is heated up to 21 °C or it is stopped when program of CFR is exited. When collector temperature rises up to 7 °C, solar circuit pump is ceased, program of CFR exits automatically.

This function is used in systems, which use water as heat transfer liquid, to avoid the freezing of solar heat transfer fluid.

Setup steps:

To access main menu TEMP, then select submenu CFR, “CFR ----” displays on screen, default set is off.



- ▶ Press “SET” button, default off “- - -” blinks.
- ▶ Repress “SET” button, to activate or deactivate this function
- ▶ Press “+”“-” button, to adjust the frost protection function, adjustable range is (-10°C~10°C) , after function activated, default set is 4°C
- ▶ Press “ESC” button to exit the menu or wait for 20 seconds to exit automatically, parameters are saved automatically.



CFR signal displays on screen, it indicates that this function is activated.

Note: this function is only available in special solar system which using no-anti-freezing liquid; this kind of system is only suitable in area where the ambient temperature is near to 0°C for only few days. If safety requirement is very high, then anti-freezing is necessary, we suggest using suitable anti-freezing liquid to avoid frost problem.

4.4.6 SMX Maximum temperature of tank

Description:

When the DT between collector T1 and Tank T2 caters the switch-on DT of circulation, solar pump is triggered, but in order to avoid the high temperature inside tank, controller will check whether the temperature (T3) of top part of tank is higher than maximum temperature of tank, when T3 is higher than preset SMX temperature, solar pump is ceased even at the case that DT caters condition. When tank temperature drops and is 2°C below the SMX, solar pump restarts when DT caters condition.

Setup steps:

To access main menu TEMP, then select submenu SMX, "SMX 70°C" displays on screen.

- ▶ Press "SET" button, parameter "70°C" blinks
- ▶ Press "+" "—" button to adjust the value of maximum temperature of tank, adjustable range is (2°C ~ 95°C) , default set is 70°C

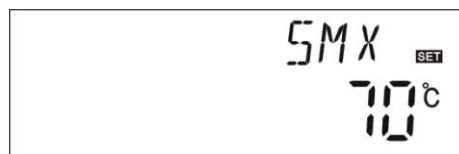

- ▶ Repress "SET" button to activate and deactivate this function, if function deactivated, "SMX - - -" displays on the screen.
- ▶ Press "ESC" button to exit the menu or wait for 20 seconds to exit automatically, parameters are saved automatically.



SMX signal displays on screen, it indicates that this function is in activated.

4.4.7 REC Tank re-cooling function

Description:

If tank temperature is over tank's maximum temperature, and at the same time, collector temperature is 5°C lower than tank temperature, then solar pump is triggered, through this reversed circulation, tank temperature is decreased by heat loss occurs in collector, solar

pump keeps in working until tank temperature drops below its maximum temperature.

Setup steps:

To access main menu TEMP, then select submenu REC, “REC OFF” displays on screen, default set is off.

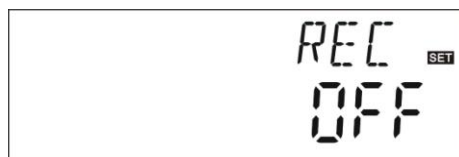

- ▶ Press “SET” button, parameter “OFF” blinks on screen
- ▶ Repress “SET” button to activate or deactivate this function, after function activated; factory set is “REC ON”
- ▶ Press “ESC” button to exit the menu or wait for 20 seconds to exit automatically, parameters are saved automatically.



REC signal displays on screen, it indicates that this function is in activated.

4.4.8 C- F Celsius and Fahrenheit temperature switch

Setup steps:

To access main menu TEMP, then select submenu C-F, “C_F °C” displays on screen.



- ▶ Press “SET” button, parameter “°C” blinks on the screen.
- ▶ Press “+” button, to select between Celsius and Fahrenheit temperature, factory set is °C
- ▶ Press “ESC” button to exit menu or wait for 20 seconds to exit automatically, parameters are saved automatically.

4.5 Main menu - FUN Auxiliary function

The auxiliary function of this controller can be set under “FUN” menu; it is possible to activate several auxiliary functions at the same time.

Note:

In “FUN “menu, some functions are deactivated, then activated or deactivated status for following auxiliary functions in submenu is also different.

Example to explain:

If you set thermal energy measuring parameter (OHQM) is off, that means this function is deactivated, then, FMAX, MEDT and MED% functions are disappeared in the submenu, only when this function (OHQM) is activated, and they just appear in the submenu. (See detailed in § 2.2 menu structure)

Following submenu can be accessed through menu “FUN”

Submenu	Menu description	Paragraph
DVWG	Anti-Legionella function	4.5.1
nMIN	Solar circuit pump speed adjusting (RPM speed controlling)	4.5.2
DTS	Standard temperature difference (for circuit pump speed adjusting)	4.5.2.1
RIS	Increase rate (for circuit pump speed adjusting)	4.5.2.2
OHQM	Thermal energy measuring	4.5.3
FMAX	Flow rate	4.5.3.1
MEDT	Type of heat transfer liquid	4.5.3.2
MED%	Concentration of anti-freezing liquid	4.5.3.3
FTYP	Type of Flow meter	4.5.4
INTV	Pump interval function	4.5.5
TSTP	Pump interval time	4.5.5.1
TRUN	Pump running time	4.5.5.2

4.5.1 DVWG Anti-Legionella function

Description:

In order to avoid occurring bacteria in water tank when the temperature of tank is lower for a long time, controller will automatically check the temperature of tank every 7 days (a period), if the temperature of tank is never over 70°C during this period, then at the default time 01:00 am on every Sunday of the period auxiliary heating system is triggered automatically to heat water until it rises up to 70°C, bacteria is killed by high temperature, whereafter function is deactivated.

Setup steps:

To access main menu FUN, then select submenu DVWG, “DVWG OFF” displays on screen. Default set is “OFF”.

▶ Press “SET” button, parameter “OFF” blinks on the screen.

▶ Re-press “+”/“-” button, “DVWG ON” blinks on the screen, function is triggered.

▶ Press “ESC” button to exit the menu or wait for 20 seconds to exit automatically, parameters are saved automatically.

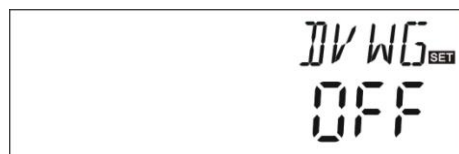

4.5.2 nMIN Solar circuit pump speed adjusting (RPM speed controlling)

Description:

P1 output can be configured to function either as RPM controlled output or simple switch output. When this function is activated, the output is RPM controlled output; when parameter is set as “nMIN”100%” the output becomes a normal switch output.

Normal switch output: circuit pump speed controlling is deactivated, pump is operated with a fixed speed, and flow rate is not changed.

RPM control output: (speed controlling is activated), the control system attempts to maintain a constant temperature difference between collector and tank. The pump performance is continuously adjusted and the volume flow of pump is increased or reduced, depending on the temperature difference.

Setup steps:

To access main menu FUN, then select submenu nMIN, “nMIN 30” displays on screen.

▶ Press “SET” button, parameter “30” blinks on the screen

▶ Press “+”“—” button, to adjust speed of circuit pump, adjustable range (30~100%), factory set is 30%

▶ Press “ESC” button to exit the menu or wait for 20 seconds to exit automatically, parameters are saved automatically.



4.5.2.1 DTS Standard temperature difference (for circuit pump's speed adjusting)

Description:

When the switch-on temperature difference (ΔT ON) reaches, solar pump is triggered, and then within 20 seconds, pump speed reaches to its minimum speed (30%). Whereafter, controller checks continuously, when the standard temperature difference (DTS) reaches, the speed of pump increases one grade (10%), temperature difference RIS increases every 1°C , speed of pump increases 10% until it reaches to its maximum speed 100%. Through setting the temperature difference increase rate (RIS) can achieve the controlling of pump speed. If temperature difference drops to the switch-off TD (ΔT OFF), circuit pump is ceased.

Setup steps:

To access main menu FUN, then select submenu DTS, “DTS 08°C” displays on the screen

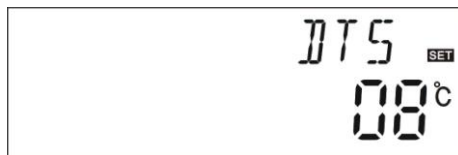

▶ Press “SET” button, parameter “08°C” blinks on the screen

▶ Press “+”“-” button, to adjust standard DTS, adjustable range (2°C~30°C) , factory set is 08°C

▶ Press “ESC” button to exit the menu or wait for 20 seconds to exit automatically, parameters are saved automatically.

4.5.2.2 RIS Temperature increase rate (for circuit pump speed adjusting)

Setup steps:

To access main menu FUN, then select submenu RIS, “RIS 01°C” displays on screen.

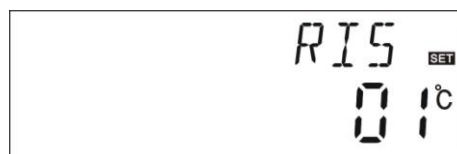

▶ Press “SET” button, parameter “01°C” blinks on the screen

▶ Press “+”“-” button, to adjust increase rate of (RIS) of temperature difference, adjustable range (1°C~20°C) , factory set is 1°C

▶ Press “ESC” button to exit the menu or wait for 20 seconds to exit automatically, parameters are saved automatically.

4.5.3 OHQM Thermal energy measuring

Description:

Controller has function for measuring thermal energy; it can measure the energy which from collector transfers to tank. For the sake of measuring, the temperature (T0, T1) on flow and return pipe should be checked, and an extra flow meter should be installed on the circulation pipe and it is used for measuring the flow rate.

The thermal energy through solar system is calculated with measured temperature T1, T0 and flow rate. Thermal energy get in the current day displays in DKWh, accumulative thermal energy displays in kWh or MWh. Day energy plus accumulated energy gets total energy output.

Setup steps:

To access main menu FUN, then select submenu OHQM, “OHQM OFF” displays on screen, Factory set is OFF

▶ Press “SET” button, parameter “OHQM OFF” blinks on the screen



▶ Repress “+”“-” button, to activate this function, “OHQM ON” blinks on the screen

▶ Press “ESC” button to exit the menu or wait for 20 seconds to exit automatically, parameters are saved automatically.

Note:

1) Thermal energy achieved in current day, accumulative thermal energy and operation time of pump can be reset, under standby status, doing like following:

▶ Press “+”“-” button, select to check the thermal energy of current day, “DKWH XX” “SET” displays on the screen.

▶ Press “SET” button for 3 seconds, buzzer makes 3 times “du-----”, the daily thermal energy is cleared, and daily thermal energy is reset to “00”.

▶ Press “+”“-” button, select to check accumulative thermal energy, “KWH XX” or “MWH XX” “SET” displays on the screen.

▶ Press “SET” button for 3 seconds, buzzer makes 3 times “du-----”, the sum thermal energy is cleared; accumulative thermal energy is reset to “00”.

▶ Press “+”“-” button, select to check operation time of pump, “hP XX” “SET” displays on the screen.

▶ Press “SET” button for 3 seconds, buzzer makes 3 times “du-----”, the operation time of pump is cleared, and it is reset to “00”.

2) Only when the thermal energy measuring function is activated, operation time of circulation pump function just can be triggered.

4.5.3.1 FMAX Flow rate

FAMX: Flow rate L/min. adjustable range: (0.1~20) L/min, increase rate 0.1L per time, factory set is 2.0L/min

Setup steps:

To access main menu FUN, then select submenu FMAX, “FMAX 2.0” displays on screen.



▶ Press “SET” button, parameter “2.0” blinks on the screen

▶ Press “+”“-” button to adjust parameter of flow rate. adjustable range (0.1~20)

▶ Press “ESC” button to exit the menu or wait for 20 seconds to exit automatically,

parameters are saved automatically.

Note: When use digital flow counter, then this function isn't existed.

4.5.3.2 MEDT Type of heat transfer liquid

MEDT: type of heat transfer liquid, adjustable range (00~03), factory set : 01

Type of heat transfer liquid:

00: Water

01: Propylene glycol

02: Glycol

03: Tyfocor LS/G-LS

Setup steps:

To access main menu FUN, then select submenu MEDT, "MEDT 01" displays on screen.



▶ Press "SET" button, parameter "01" blinks on the screen

▶ Press "+" "-" button, to adjust type of heat transfer liquid, adjustable range (00~03)

▶ Press "ESC" button to exit the menu or wait for 20 seconds to exit automatically, parameters are saved automatically.

4.5.3.3 MED% Concentration of heat transfer liquid

MED% Concentration of heat transfer liquid (volume percentage %), depending on the type of heat transfer liquid, adjustable range (20 ~70), factory set 40%

Setup steps:

To access main menu FUN, then select submenu MED%, "MED% 40" displays on screen.



▶ Press "SET" button, parameter "40" blinks on the screen

▶ Press "+" "-" button to adjust concentration, adjustable range (20~70)

▶ Press "ESC" button to exit the menu or wait for 20 seconds to exit automatically, parameters are saved automatically.

Note: when MEDT type of transfer liquid is "00, 03", MED% cannot be displayed.

4.5.4 FTYP Type of Flow meter (optional)

FTYP: type of flow meter, adjustable range (01, 02)

Type of flow meter: 01: mechanical flow meter

02: digital flow meter

Under FUN main menu , select FTYP submenu, “FTYP 01” displays on the screen.

▶Press” SET” button, parameter “01” blinks on the screen.

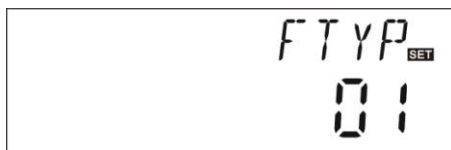

▶Press “+” “-”button to adjust the type of flow meter, adjustable range (01, 02)

▶Press “ESC” button to exit menu, or wait for 20 seconds to exit automatically, the set value of parameter is saved automatically.

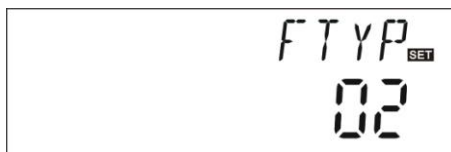

4.5.5 INTV Pump interval function

Description:

This function is useful when collector sensor isn't installed on collector (sensor installed on the outlet pipe of collector). In order to measure the actual temperature of collector, within the preset interval, solar pump is triggered for short time, so that the hot water inside collector can flow to the pipe, where sensor is mounted, as the result, the actual temperature of collector is measured. It is unnecessary to activate this function for all time, you can use it within a preset schedule.(default set time is 06:00 ~20:00,not change)

During the period that solar pump is in operating, (the period of running time can be set by parameter “tRUN”), controlled check the temperature increase of sensor, if the temperature increases is less than 1°C, then solar pump is ceased automatically. After the break time (interval can be set by parameter “tSTP”), same process repeats.

During the period that solar pump is in operating, if measured temperature increases is over 1°C, then the next interval is omitted, this omitting repeats when it caters condition and until the switch-on temperature difference is catered or no more temperature change can be measured. After that, pump interval function recovers to pulse rate-controlled mode.

Setup steps:

To access main menu FUN, then select submenu INTV, “INTV OFF” displays on screen.

▶ Press “SET” button, parameter “OFF” displays and blinks, factory set is “OFF”

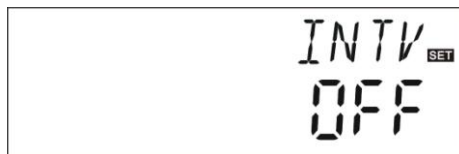

▶ Press “+”“-” button, to activate this function, “INTV ON” displays on the screen.

▶ Press “ESC” button to exit the menu or wait for 20 seconds to exit automatically, parameters are saved automatically.

4.5.5.1 tSTP Pump interval- time

Setup steps:

To access main menu FUN, then select submenu tSTP, “tSTP 30” displays on screen.



▶ Press “SET” button, parameter “30” blinks on screen, factory set is “30” minutes.

▶ Press “+”“-” button to adjust the loading time, adjustable range: 2~60 minutes,

▶ Press “ESC” button to exit the menu or wait for 20 seconds to exit automatically, parameters are saved automatically.

4.5.5.2 tRUN Pump running time

Setup steps:

To access main menu FUN, then select submenu tRUN, “tRUN 15” displays on screen.



▶ Press “SET” button, parameter “15” blinks on screen, factory set is 15 seconds. .

▶ Press “+”“-” button to adjust the running time, adjustable range: 5~120 seconds

▶ Press “ESC” button to exit the menu or wait for 20 seconds to exit automatically, parameters are saved automatically.

4.6 HND Manual mode

When using this controller first time or when debugging this controller, output of this controller (P1, H1) can be triggered manually “On, OFF” control.

Setup steps:

To access main menu HND,

▶ Press “SET” button, “HND1 off” displays on the screen, P1 output manually set



▶ Repress “SET” button, “HND1 on” displays on the

screen, P1 output is switched-on

- ▶ Repress “SET” again, “HND1 off” displays, P1 output is switched-off
- ▶ Press “ESC” to exit P1 set program

-
- ▶ Press “+” button, “HND2 off” displays on the screen, H1 output manually set
 - ▶ Press “SET” button, “HND2on” displays on the screen, H1 output is switched-on
 - ▶ Repress “SET” again, “HND2off” displays, H1 output is switched-off

- ▶ Press “ESC” to exit H1 set program
- ▶ Press “ESC” to exit H1 set program



4.7 PASS Password setting

Setup steps:

To access main menu PASS,

- ▶ Press “SET” button, “PWDC 0000”, the left digital blinks, ask for to enter the password, factory set is “0000”

- ▶ Press “+”“-” button to enter the first digital
- ▶ Repress “SET” button, the second digital blinks
- ▶ Press “+”“-” button to enter the second digital
- ▶ Repress “SET” button, the third digital blinks
- ▶ Press “+”“-” button to enter the third digital
- ▶ Repress “SET” button, the fourth digital blinks
- ▶ Press “+”“-” button to enter the fourth digital
- ▶ Press “SET” button, “PWDN 0000” displays on the screen, ask for entering a new password, doing like above to enter the new password

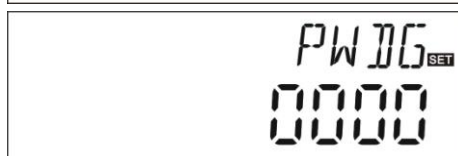
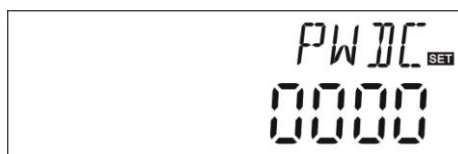



- ▶ Press “SET” button, “PWDG 0000” displays on the screen, ask for reentering the new password, doing like above to reenter the new password, “PWOK” displays on the screen to indicate reentering password successfully.
- ▶ Press “ESC” button to exit set program or wait for 20 seconds to exit automatically.



Warning !

If the password is forgot, it is not possible to recover, but you can recover the password to factory set, then you can reedit a new password like above descript steps, doing like following to recover to factory set.

- ▶ Open the cover of display,
- ▶ Press  and hold down, then switch-off the power of controller, wait several seconds, then switch-on power again. Buzzer makes “du-----” 3 times, then release  button. Controller recovers to factory set, a new password can be reset now.

4.8 LOAD Recovery factory setting

Setup steps:

To access main menu LOAD,

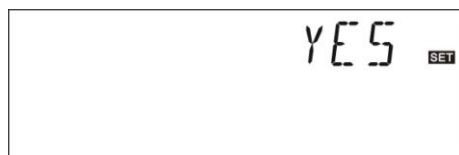

- ▶ Press “SET” button, “YES” displays on the screen.
- ▶ Hold down “SET” button, buzzer makes “du-----” 3 times, then release “SET” button. Controller recovers to factory set, new paramters can be reset now.



- ▶ Press “ESC” button to exit set program or wait for 20 seconds to exit automatically.

4.9 On/OFF button

Under the standby status,

- ▶ Press  button for 3 seconds; controller is switched off, “OFF” displays on the screen.
- ▶ Repress  button, controller is switched-on again.

4.10 Holiday function

Description:

This function activates at night, solar liquid will flow from storage tank to collector to cool the tank, and therefore to prevent high thermal loads problem of the solar system due to completely heated storage tank. The function is activated at night between 10 pm and 6 am, when the collector temperature drops 8 °C below the storage tank temperature (T2), solar

circuit pump starts to work; when the temperature of collector is 2°C below the tank temperature, and solar circuit pump is ceased.

Activate this function if:

- You intend to be absent for an extended period (holiday)
- No hot water is required for an extended period.

Note: The function is deactivated when the temperature in lower section of storage tank falls down to 35°C.

Activate/ deactivate this function:

▶ Press “Holiday” button for a long time until the signal of holiday function displays on the screen, and then holiday function is activated.

▶ Repress “Holiday” button, signal disappears, holiday function is deactivated.

Note:

This function is only activated when you are not at home for long time, when you come back; please make sure to deactivate it.

4.11 Manual heating

Description:



Electrical heater, gas or oil boiler can be as back-up devices in a solar system, this controller can achieve constant temperature controlling, when controller gets temperature signal of top part tank (T3) is 2°C below the preset temperature, back-up heating will be triggered. When temperature of top part tank (T3) reaches to the preset temperature, heating is ceased.

Conditions for triggering manual heating function: the setting temperature should be 2°C higher than tank temperature.

Activate/deactivate the function:

▶ Press “Man.Heat” button, temperature “60°C” blinks on the screen.

▶ Press “+”“-” button to adjust switch-on temperature, adjustable range 10°C~80°C, factory set is 60°C.

After 20 seconds, this function is activated, signal  displays on the screen, and  heating signal blinks also. LED heating indication light is on.

▶ Press “Man.Heat” button again, to switch-off manual heating function.

Note: manual heating can only heat tank one time, after manual heating is triggered, when temperature of tank rises up to the preset temperature, manual heating ceases, and manual heating function will be deactivated automatically, if customer wants to heat again, you need redo according to above steps.

4.12 Temperature check

Under standby status,

▶ Press “+”“-” button can check the value of temperature sensors T0~ T3, pump speed (n %), accumulative operation time of circuit pump (Hp), daily thermal energy (DKWH), accumulative thermal energy (KWH) or (MWH), Flow rate (L/M) .

When checking temperature, T0 – T3 will displays one by one, corresponding sensor signal  blinks.

▶ Press “ESC” button, week and tank temperature can be displayed.

Note:

1. Value of accumulative operation time of circuit pump (Hp), daily thermal energy (DKWH) and accumulative thermal energy (KWH) or (MWH) can only be checked after triggering of QHQM thermal energy balance function.
2. Flow rate (L/M) can be displayed when digital flow counter is used in solar system. If mechanical flow counter is used, then flow rate can't display.

5. Protection function

5.1. Memory protection

In case power failure occurs, controller keeps the parameter settings unchanged.

5.2 Screen protection

When no any press on button for 3 minutes, screen protection is activated automatically, and then LCD lighting lamp is switched-off. Through press any button to light LCD lamp again.



6. Trouble shooting

6.1 Trouble protection

a. When there is a break or short circuit between the connection of temperature sensors, controller switches off the corresponding functions and no more output signals are given, at the same time error signals  are showed on the display.

If controller does not work correctly, please check following points.



► Press “+”“-” button to check error code, “  “signal displays on the LCD screen

Error message on LCD screen	Meaning	Cause of error	Error rectification
 T0 ---	T0 sensor problem	Sensor wiring interrupted, not connected or short circuit	Check resistance value, replace
	Thermal measuring function is switched-on	T0 sensor not connected	Connect T0 or switch-off this function (OHQM)
 T1 ---	T1 sensor problem	Sensor wiring interrupted, not connected or short circuit	Check resistance value, replace
 T2 ---	T2 sensor problem	Sensor wiring interrupted, not connected or short circuit	Check resistance value, replace

6.2 Trouble checking

The controller is quality product, conceived for years of continuous trouble-free operation. If a problem occurs, the cause of the problem very often lies not in the controller but in the

peripheral components. The following description of some well-known problems should help the installer and operator to isolate the problem, so that the system can be placed back into operation as quickly as possible and to avoid unnecessary costs. Of course, not all possible problems can be listed here. However, most of the normal problems encountered with the controller can be found in the list below, only return the controller to seller when you are absolutely sure that none of the problems listed below is responsible for the fault.

Symptoms	Secondary symptoms	Possible cause	Procedure
Controller does not display any functions at all	Display shows nothing, no display illumination	Controller power supply is interrupted or program is out of work	Check the controller power cable Press reset button
The solar pump doesn't operate, despite the fact that switch-on conditions are satisfied	The pump symbol on the display blinks	Pump power supply is interrupted	Check the pump power cable
Pump doesn't operate	The pump symbol on the display doesn't blink.  Lighted or  blinks	The maximum storage tank temperature (SMX) is reached The maximum collector temperature (EM) is reached.	No fault
	 T1-----Error message displays on the screen	Fault (short circuit or open circuit) in a temperature sensor	On the controller, check the current values of all connected temperature sensors, replace all defective sensors and /or cabling.
The solar pumps operated, despite the fact that the switch-on conditions are not satisfied.	The pump symbol on the display blinks.	Holiday function or Frost protection function or tank re-cooling function is activated.	No problem, it is normal. If necessary to deactivate the corresponding functions.



Warning! Remove the device from the mains supply before opening the case

A potentially defective sensor can be checked using an ohmmeter. To do this, the sensor must be disconnected, its resistance measured, and the value compared with the figures in the table below, small deviation ($\pm 1\%$) is acceptable,

PT1000 resistance value

°C	0	10	20	30	40	50	60	70	80	90	100
Ω	1000	1039	1077	1116	1155	1194	1232	1270	1309	1347	1385

NTC 10K B=3950 resistance value

°C	0	10	20	30	40	50	60	70	80	90	100
Ω	33620	20174	12535	8037	5301	3588	2486	1759	1270	933	697

7. Quality Guarantee



Manufacturer provides following quality responsibilities to end-users: within the period of quality responsibilities, manufacturer will exclude the failure caused by production and material selection. A correct installation will not lead to failure. When a user takes incorrect handling way, incorrect installation, improper or crud handling, wrong connection of sensor in system and incorrect operation, the quality responsibility is invalid for them.

The warrantee expires within 24 months after the date of purchasing the controller.

8. Technical data

Specification	Data
Power supply	AC230V±10%
Power consumption	< 3W
Accuracy of temperature measuring	±2°C
Range of collector temperature measuring	-10~220°C
Range of tank temperature measuring	0~110°C
Suitable power of pump	1 pump, ≤ 500W
Suitable power of electrical heater	1 heater, ≤ 1500W
Inputs	1 x Pt1000 sensor (≤500°C) for collector (silicon cable≤280°C), 2 x NTC10K, B3950 sensor (≤ 135°C) for tank, (PVC cable ≤105°C),
Outputs	1 relay for circulation pumps 1 relay for electrical heater
Ambient temperature	-10~50 °C
Water proof grade	IP40

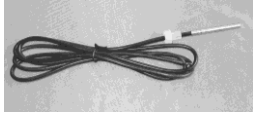
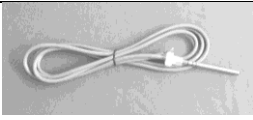
9. Accessories to this controller

<p>A01: sensor for collector</p>	<p>PT1000, $\Phi 6 \times 50\text{mm}$</p>	
<p>A02: sensor for tank and pipe</p>	<p>NTC10K, B=3950, $\Phi 6 \times 50$</p>	
<p>A05: stainless steel thermowell</p>	<p>Parameter: 1/2' OT, $\Phi 8 \times 200$</p>	
<p>SR802: unit for high power electrical heater</p>	<p>Dimension: 100mmx100mmx65mm Power supply: AC180V ~ 264V, 50/60Hz Suitable power: $\leq 4000\text{W}$ Available ambient temperature: $-10 \sim 50^\circ\text{C}$ Waterproof grade: IP43</p>	

SR802 connection diagram:

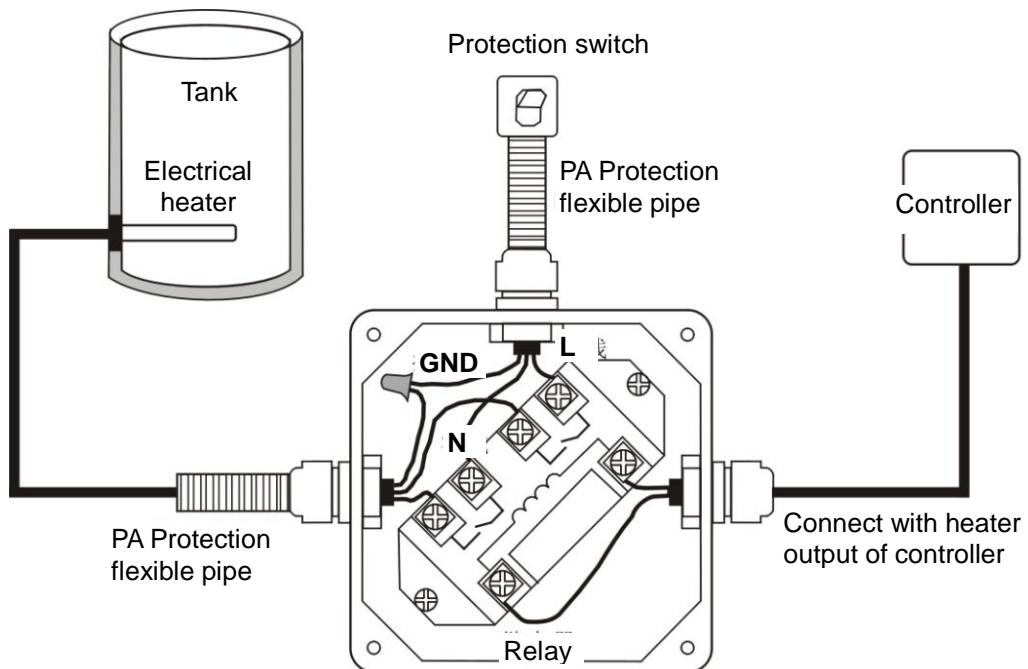

Note: switch-off power, and perform by profession installer