

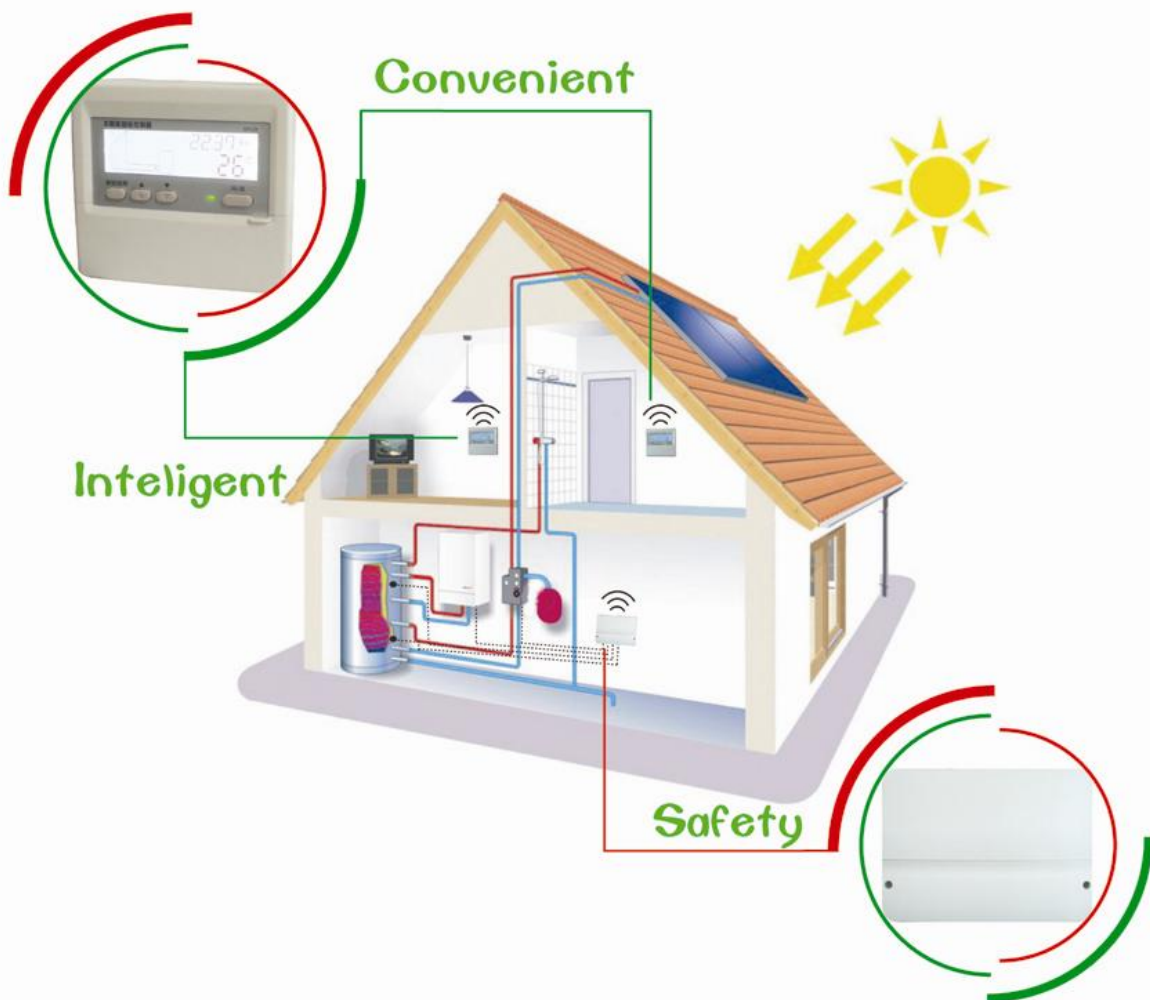

Installation and Operating Manual

For Split Pressurized Hot Water System

Wireless Controller SR528



 Read the instruction carefully please operation!

Contents

1. Safety information	3
1.1 Installation and commissioning.....	3
1.2 About this manual	3
1.3 Liability waiver	3
1.4 Important remark.....	4
1.5 Description of symbols.....	4
1.6 Operation button	4
2. Installation of controller	6
2.1 Display installation	6
2.2 Controller installation.....	7
2.3 Preparation before wire connection	7
2.4 Wire collocation	7
2.5 Wire connection.....	8
3. Wireless connection.....	10
3.1 Code match between controller and display	10
3.2 Application of wireless controller	12
4. Debugging	13
4.1 Time/week setup	13
4.2 Menu structure.....	14
4.3 Menu description.....	15
4.4 System description	16
5.Functions operation and parameters setup (user grade).....	17
5.1 Timing Heating.....	17
5.2 Energy save mode.....	20
5.3 Temperature / time setting for DHW circulation pump.....	21
6. Functions operation and parameters setup (engineer grade).....	24
6.1 Access main menu.....	24
6.2 Access submenu	25
6.3 Temperature difference for solar circuit pump (DT O/DT F)	25
6.4 TEMP Temperature main menu.....	27
6.4.1 EMOF Maximum switch-off temperature of collector (for collector emergency close function)	27
6.4.2 EMON Maximum switch-on temperature of collector (for collector emergency	

close function)	28
6.4.3 CMX Maximum limited temperature of collector (collector cooling function)	29
6.4.4 CMN Low temperature protection of collector	30
6.4.5 CFR frost protection temperature of collector	30
6.4.6 SMX Maximum temperature of tank.....	31
6.4.7 REC Cooling temperature of tank.....	32
6.4.8 C_F Switch between Celsius and Fahrenheit.....	33
6.5 FUN Auxiliary functions.....	33
6.5.1 DVWG Anti legionnaires' function.....	34
6.5.2 CIRC DHW circulation pump on/off	34
6.5.3 COOL Tank cooling function	34
6.5.4 BYPR Bypass function (high temperature)	35
6.6 COMM Communication function menu	36
6.6.1 ID Address	36
6.6.2 MAC Network address.....	37
6.6.3 FREQ Communication frequency.....	37
6.6.4 RSSI Signal intensity	37
6.7 HND Manual control	37
6.8 PASS Password set.....	39
6.9 LOAD Recovery to factory set.....	39
6.10 "ON/OFF" Controller switch on/off button.....	40
6.11 Holiday function.....	40
6.12 Manual heating.....	41
6.13 Temperature query function	41
7. Protection function	42
7.1. Memory protection	42
7.2 Screen protection.....	42
8. Trouble shooting	43
8.1 Trouble protection	43
8.2 Trouble checking.....	44
9. Quality Guarantee	45
10. Technical specification	46
11. Package list.....	47
12. Device matched to this controller	47

1. Safety information

1.1 Installation and commissioning

- When laying cables, please ensure that no damage occurs to any of the constructional fire safety measures presented in the building.
- The controller must not be installed in rooms where easily inflammable gas mixtures are present or may occur.
- The permissible environmental conditions can't be exceeded at the site of installation.
- Before connecting the device, make sure that the energy supply matches the specifications that controller requires.
- All devices connected to the controller must conform to the technical specifications of the controller.
- All operations on an open regulator are only to be conducted cleared from the power supply. All safety regulations for working on the power supply are valid.
- Connecting and /or all operations that require opening the regulator (e.g. changing the fuse) are only conducted by specialists.

1.2 About this manual

This manual describes the installation, functions and operation of a solar thermal controller. When installing the remaining components e.g. the solar collectors, pump stations and the water storage, it should be sure to observe the appropriate installation instructions provided by each manufacturer. Only trained professional personnel may perform installation, electrical connection, commissioning and maintenance of the device. The professional personnel must be familiar with this manual and follow the instructions contained herein.

1.3 Liability waiver

The manufacturer cannot monitor the compliance with these instructions or the circumstances and methods used for installation, operation, utilization and maintenance of this controller. Improper installation can cause damages to material and person. This is the reason why we do not take over responsibility and liability for losses, damages or cost that might arise due to improper installation, operation or wrong utilization and maintenance or that occurs in some connection with the aforementioned. Moreover we do not take over liability for patent infringements or infringements – occurring in connection with the use of this controller- on third parties rights. The manufacturer preserves the right to put changes to product, technical data or installation and operation instructions without prior notice. As

soon as it becomes evident that safe operation is no longer possible (e.g. visible damage). Please immediately take the device out of operation. **Note: ensure that the device cannot be accidentally placed into operation.**

1.4 Important remark

We have carefully checked the text and pictures of this manual and provided the best of our knowledge and ideas, however inevitable errors maybe exist. Please note that we cannot guarantee that this manual is given in the integrity of image and text, they are just some examples, and they apply only to our own system. Incorrect, incomplete and erroneous information and the resulting damage we do not take responsibility.

1.5 Description of symbols



Safety instruction:



The safety instructions in the manual are marked with a warning triangle. They indicate measures, which can lead to personal injury and safety risks.

Operation steps: small triangle “▶” is used to indicate operation step.

Notes: Contains important information about operation or function.

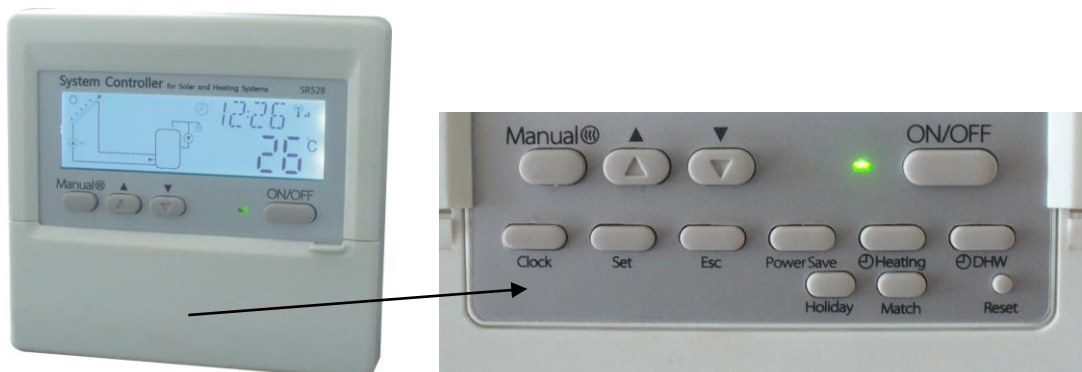
1.6 Operation button



Button	Button function description
ON/OFF	Controller switch on/off;Manually control DHW pump
Clock	Time setting
Manual 	Manual starting heating button
Set	Setup parameters
▲	Parameters upwards adjust
▼	Parameters downwards adjust
Esc	Exit
Power Save	Power save mode starting button
 Heating	Timing heating starting button
 DHW	DHW timing circulation starting button
Holiday	Holiday mode
Match	Code match
Reset	Parameters reset

2. Installation of controller

Controller can be only installed indoors, not installed in a dangerous and moist place and far away from the electromagnetic field.

2.1 Display installation

- ▶ Determine the mounting site of display.
- ▶ Mount the base board on an 86 type wire connection box.
- ▶ Hang the display on the base board and rivet it with screw.
- ▶ Put the cover on the display

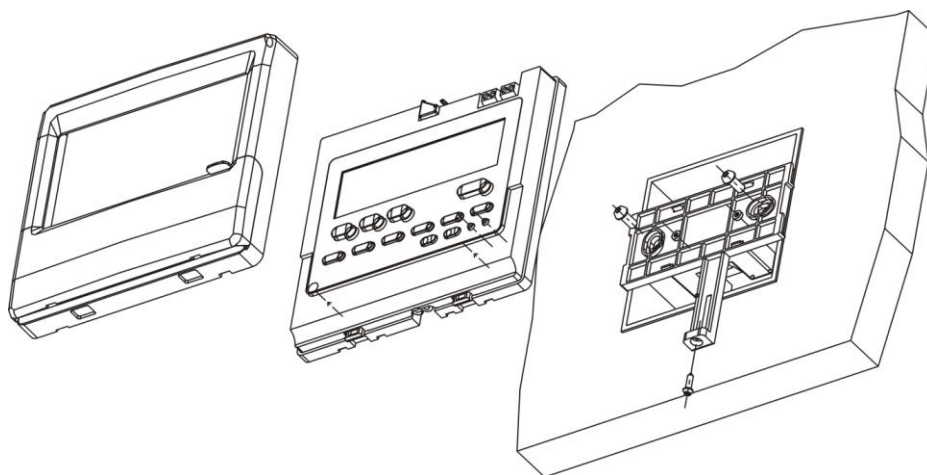

Demount the cover of display

- ▶ Unclench the bottom fix hook of display with a flat “-“screw driver,
- ▶ Upwards unclench the cover with another flat “-“screw driver,

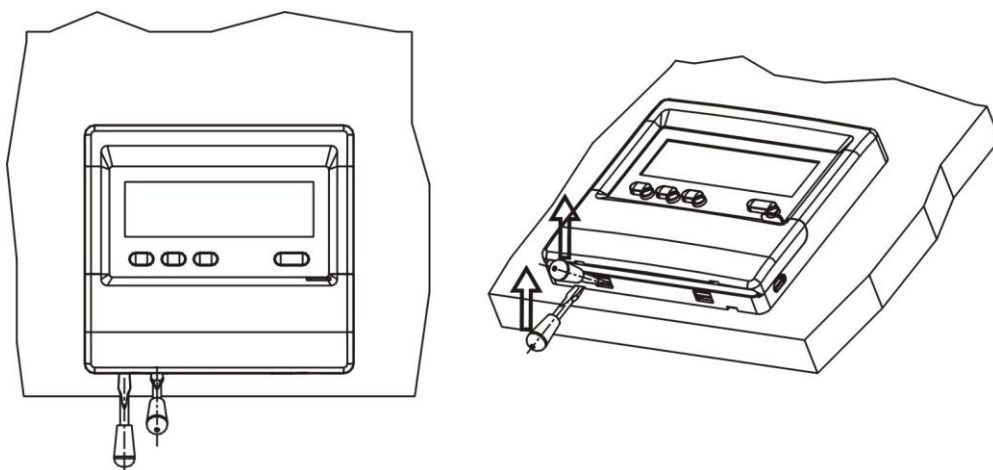

2.2 Controller installation



Controller can only be installed in an area having an adequate level of protection.

Fix the base board of controller

- ▶ Determine the mounting site of controller.
- ▶ Fix the base board on the wall with plastic expand screw
- ▶ Hang the controller on the base board.

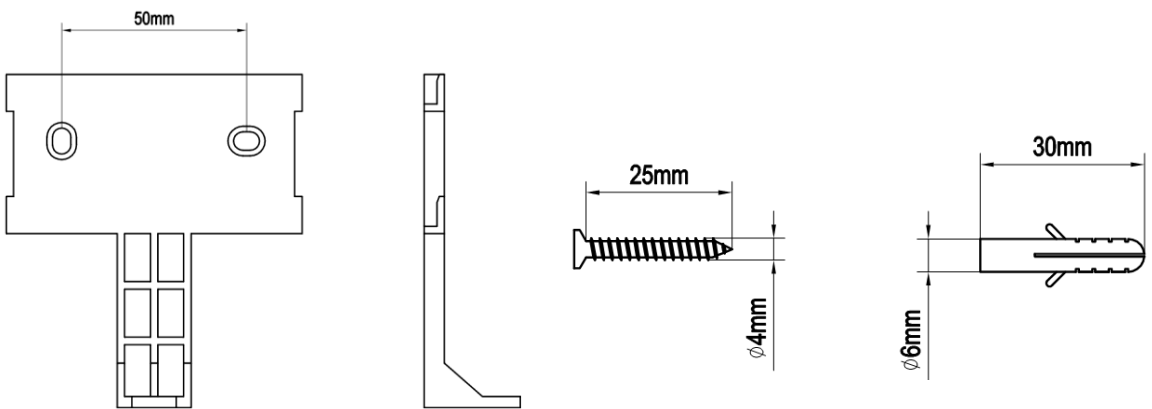

2.3 Preparation before wire connection

Open/Close the wire terminal cover

- ▶ Loosen the screw ①②, upwards move the terminal cover and take off the cover
- ▶ Cover reset: downwards the cover
- ▶ Fix it with screw on position ①②.

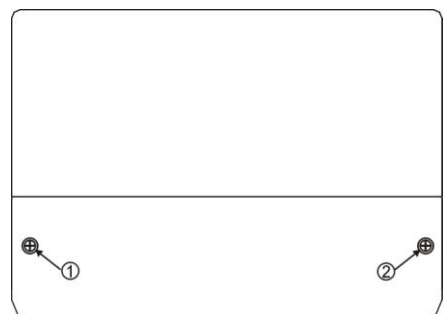

2.4 Wire collocation

Switch-on power only when cover of the controller is closed and installer should ensure the IP safety protection is not damaged during the installation process.

Depending on the type of installation, the cables may enter the controller through the rear

hole of the case ④ or the lower side hole of the case ⑤.

Cable enters from the rear hole④ : Remove the plastic flaps ④ from the rear side of the case using an appropriate tool.

Cable enters from the below hole⑤ : Cut the left and right plastic flaps using an appropriate tool (e.g. knife) and break them out of the case.

Notes: the flexible wire must be fastened on the case using the clamps⑥ provided.

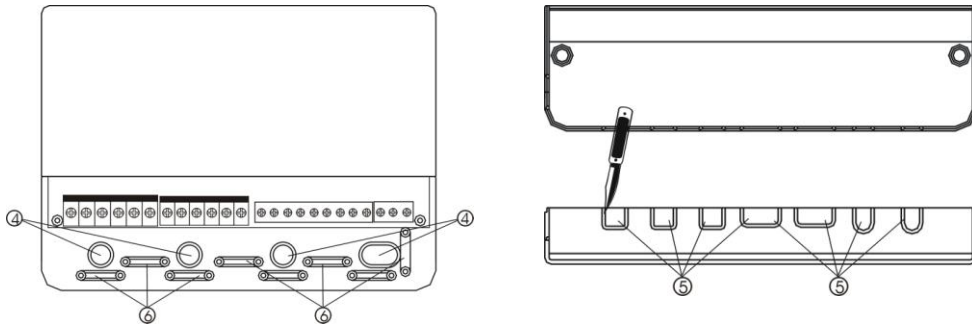

2.5 Wire connection



Before open the wire connection terminal, please be sure to switch-off the power and conform to the instructions of local power supply.

● Terminal layout

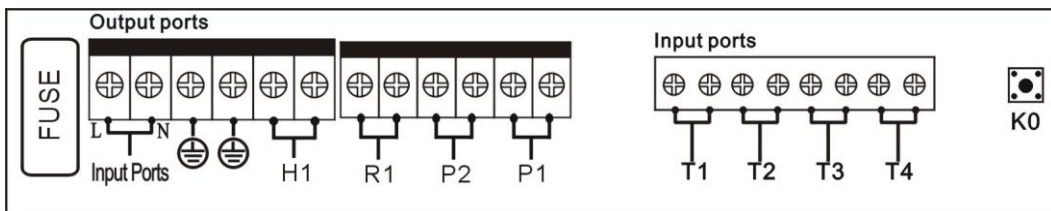

● Power connection ports

Input Ports: is for power connection, connect L, N wire correctly.



: is ground port.

- FUSE:2A/250V
- K0: Code match button of controller
- **Temperature sensor inputs**

Input T1: For PT1000 temperature sensor, used to measure the temperature of

collector

Input T2~T4: For NTC10K, B=3950 temperature sensor, used to measure the temperature of tank or pipe

- **Advice regarding the installation of temperature sensors**

- Only original factory enclosed Pt1000 temperature sensors are approved for use with the collector, it is equipped with 1.5meter silicon cable and suitable for all weather conditions, the temperature sensor and cable are temperature resistant up to 280°C, not necessary to distinguish the positive and negative polarity of the sensor connection.
- Only original factory enclosed NTC10K, B=3950 temperature sensors are approved for use with tank and pipe, it is equipped with 3.0meter PVC cable, and they are temperature resistant up to 105°C, not necessary to distinguish the positive and negative polarity of the sensor connection.
- All sensor cables carry low voltage, and to avoid inductive effects, must not be laid close to 230 volt or 400-volt cables (minimum separation of 100mm)
- If external inductive effects are existed, e.g. from heavy current cables, overhead train cables, transformer substations, radio and television devices, amateur radio stations, microwave devices etc, then the cables to the sensors must be adequately shielded.
- Sensor cables may be extended to a maximum length of ca. 100 meter, when cable's length is up to 50m, and then 0.75mm² cable should be used. When cable's length is up to 100m, and then 1.5mm² cable should be used.

- **Outputs**

Output (P1): Electromagnetic relay, for DHW circulation pump, Max. Switching current: 3.5A. P2 output port: normal status is open

Output (P2): Electromagnetic relay, for DHW circulation pump, Max. Switching current: 3.5A. P2 output port: normal status is open

Output (R1): Electromagnetic relay, for circulation pump or valve, Max. Switching current: 3.5A. R1 output port: normal status is open

Output (H1): Electromagnetic relay, for back-up electrical heater , Max. Switching current: 10A. H1 output port: normal status is open

3. Wireless connection

Before power switched-on, connect the sensor on the input ports; connect pump or valve on the output ports.

Power switched-on, first of all to match the code between controller and display, then to set up time, password and relevant parameters of system.

Note: the display is powered on, but before it is matched with controller, E1 shows on the screen,

it means data is not synchronized, after successful code matching, controller just enters a orderly operation status.

3.1 Code match between controller and display

- ▶ Open the connection terminal of controller; switch on the power of controller and display.
- ▶ Press K0 button (on the right side of controller terminal) for three seconds until the LED indicator light (on the right side of controller) blinks (1 second 1 blink)
- ▶ then release K0 button, wait for match of display.

Note:

When there is only a display in the system, then set the code "ID01" for this display.

When there are several displays in the system, then set the start code "ID01" for the first display, the code of every display should be different and not repeated.

- ▶ Press "Match" button of display 1 for 3 seconds, "ID 01" blinks on the screen.
- ▶ Press "▲ ▼" button, adjust the address of display, adjustable range is 01-08, maximum 8 displays can be matched with this controller. (Code of the first display must be set as "ID 01", the second display must be set as "ID 02", set like this, one by one)

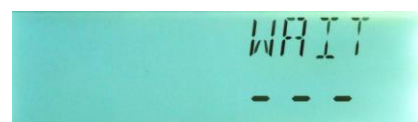
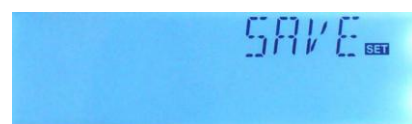
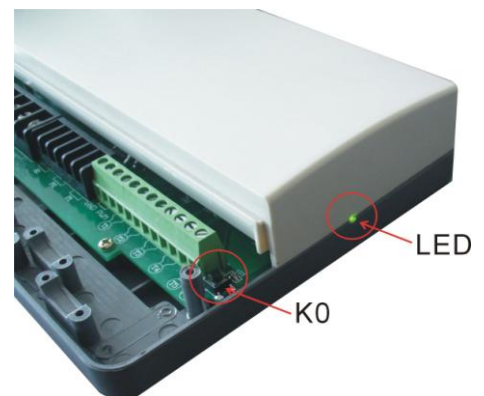

- ▶ Press “Match” button on the display, “SAVE” shows on the screen,
- ▶ Press “Match” button on the display, “WAIT - -“shows on the screen, (waiting for the connection between controller and display), it indicates “OK” when success of code match, after 6 seconds, the display “A” automatically returns to the normal operation screen,

If “WAIT- - “shows on the screen always, it indicates the un-success of code match, this display’s installation place is not suitable (distance to the controller may be too far), remount the display in a suitable place.

When 2 or above 2 displays in the system

- ▶ Press the “Match” button of display 2 for 3 seconds, “ID 01” blinks on the screen.
- ▶ Then press “ ▲ ▼” button to adjust the ID address of display, adjustable range is 01-08, and set “ ID 02” for the second display.
- ▶ Press “Match” button on the display, “SAVE” shows on the screen, save the above set.
- ▶ Press “Match” button on the display, “WAIT - -“shows on the screen, (waiting for the connection between controller and display), display automatically returns to the normal operation screen in 6 seconds.

(According to the configured displays quantity, set the ID code and match the code for every display one by one, and please note the ID code should not be repeated.)

After success code match for all displays,

- ▶ Press “KO” button for 3 seconds, the indicator light on the right side of controller shines without blink (continuously shine).
- ▶ Then release “KO” button, code match finishing, controller enters the orderly communication status.

Note: After the code match, you can press “ ▲ ▼” button to check the current signal intensity (RSSI), if you encounter the problem like signal is too weak, communication is unstable, lots of same frequency interfere signals occur nearby, you can modify the communication frequency and select a ideal frequency under the menu “COMM” (to modify the frequency must start from the display with ID address of “ ID 01”), detailed steps see paragraph 6.7.3 (433M is an ideal communication frequency; do not change it at unnecessary case).

3.2 Application of wireless controller

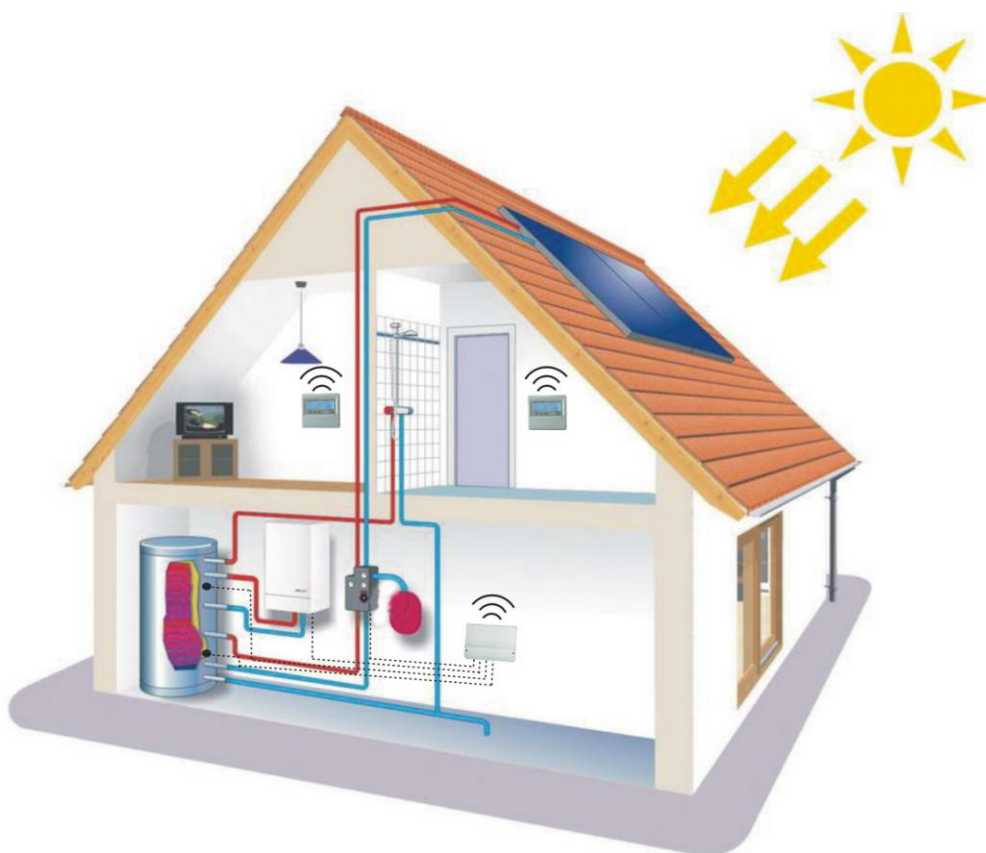

Note: standard delivery package includes 1 controller and 1 display. Extra displays should be ordered separately, 1 controller can be matched with maximum 8 displays.

4. Debugging

4.1 Time/week setup

▶ Press “Clock” button, display shows time on the screen, hour “00” blinks on the screen.

▶ Press “ ▲ ▼ ” button to adjust the hour,

▶ Press “Clock” again, minute “00” blinks,

▶ Press “ ▲ ▼ ” button to adjust the minute,

▶ Then press “Clock” again, week “MO” blinks on the screen

▶ Press “ ▲ ▼ ” to adjust day of week,

▶ Press “Esc” button to exit the system setting, or waiting for 20 seconds to exit automatically.

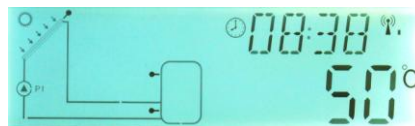

Code	Week
MO	Monday
TU	Tuesday
WE	Wednesday
TH	Thursday
FR	Friday
SA	Saturday
SU	Sunday

4.2 Menu structure

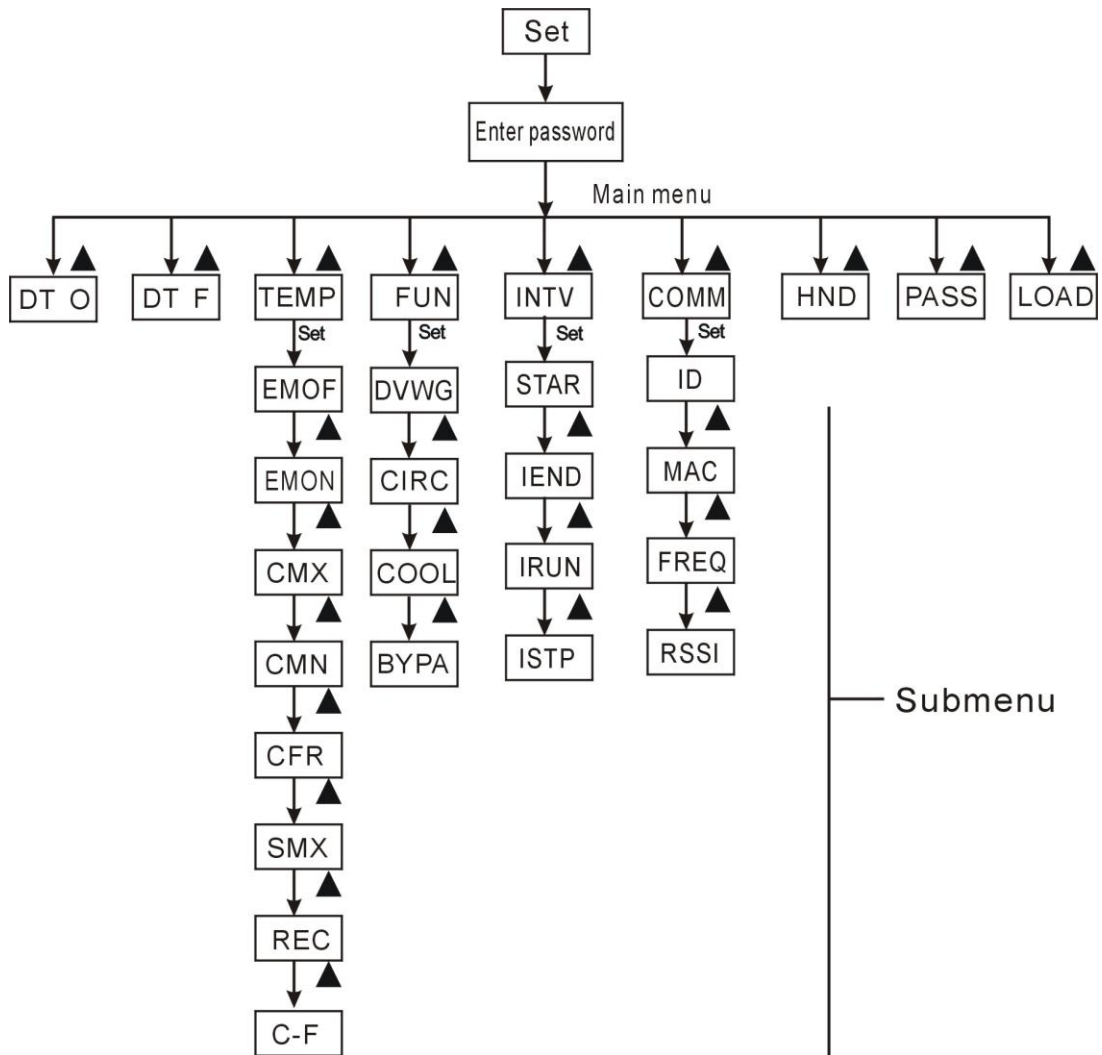

Submenu:

Through submenu, user can set the parameter as desired value, please check it carefully.

4.3 Menu description

Code (Main menu)	Code (Submenu)	Code (Submenu)	Code description
DT O			Switch-on temperature difference
DT F			Switch-off temperature difference
TEMP			Temperature menu
	EMOF		The maximum switch-off temperature of collector
	EMON		The maximum switch-on temperature of collector
	CMX		The maximum temperature of collector (Collector cooling function)
	CMN		Low temperature protection of collector
	CFR		Frost protection temperature of collector
	SMX		Maximum temperature of tank
	REC		Cooling temperature of Tank
	C-F		Switch between Celsius and Fahrenheit
FUN			Auxiliary functions
	DVWG		Anti legionnaires' function
	CIRC		DHW circulation pump on/off
	COOL		Tank cooling function
	BYPA		Bypass (high temperature)
COMM			Communication function menu
	ID		ID code of displays
	MAC		Network address
	FREQ		Communication frequency
	RSSI		Signal intensity
HDN			Manual controlling
PASS			Password set
LOAD			Recovery to factory set

4.4 System description

Note: storage temperature sensor T3 is an optional sensor, if this sensor is not installed on the upper part of the storage, controller will adopt the temperature signal from sensor T2 installed on the bottom part of storage to control back-up heater or circuit pump.

1 collector array- 1tank -1 circuit pump-back-up heater

System description:

Controller compares the temperature between collector T1 and storage T2 (bottom part), if the temperature difference (DT) rises up to the preset switch-on ($\Delta T1$) or is over it, circuit pump P1 is triggered , and then storage is heated until DT drops to the switch-off DT or when the storage temperature T3 rises up to its preset maximum temperature. Then circuit pump P1 is ceased.

Back-up heating: (see details at paragraph 5.4)

Within the preset heating time section, if tank temperature (T3) drops to the switch-on temperature of heating, then back-up heater H1 is triggered automatically, when tank temperature T3 rises up to the preset switch-off temperature, then output H1 is closed.

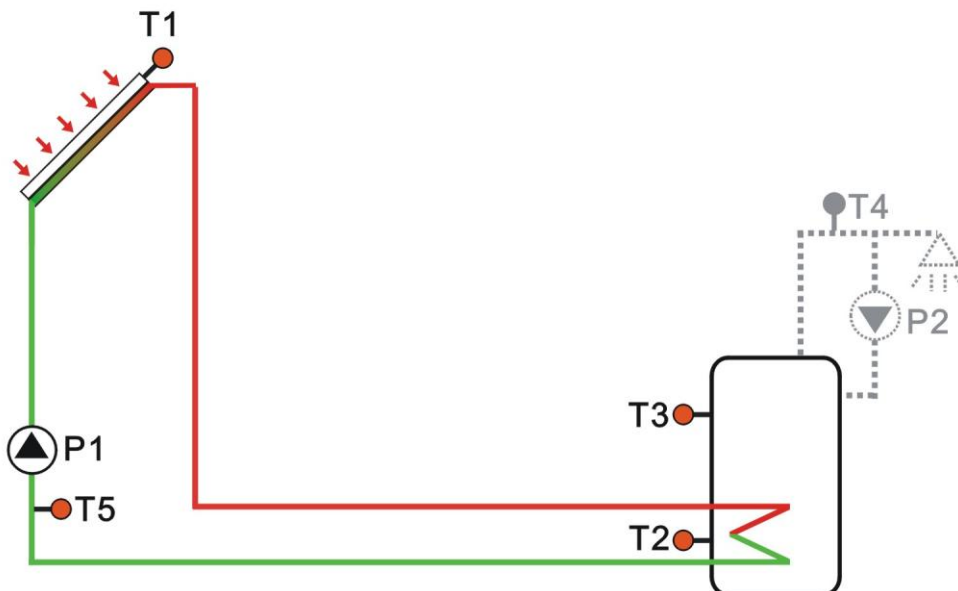
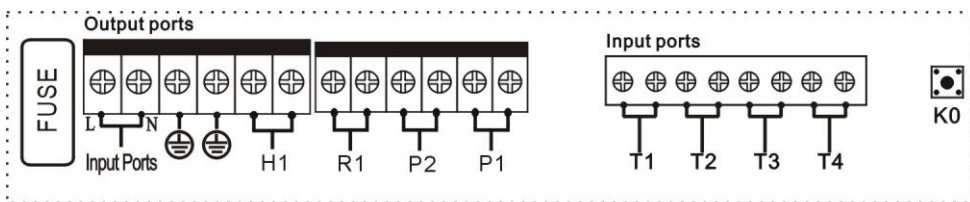

T1: Temperature sensor Pt1000 on collector

T2: Temperature sensor NTC10K on the bottom part of tank

T3: Temperature sensor NTC10K on the top part of tank (optional)

T4: Temperature sensor NTC10K on the DHW pipe (optional)

P1: Solar circuit pump

P2: DHW circuit pump

R1: High temperature bypass pump or valve (optional)

H1: Back-up heater

5.Functions operation and parameters setup (user grade)

5.1 Timing Heating

Description:

Electrical heater, gas boiler or oil boiler can be integrated into solar system used as back-up heat source, and they can be triggered automatically at preset schedule by preset temperature. Within a preset schedule, when the temperature (T3) of top part of tank drops below the preset switching-on temperature of this function, back-up heating H1 starts to work, when T3 rises up to the preset turning off temperature, back-up heating H1 is stopped. Within 24 hours, three time sections can be set with this controller.

Factory set:

The first schedule: back-up heating function starts at 4:00 and ends at 5:00 am. Within this time section, default switch-on temperature is 40°C; default switch-off temperature is 45°C.

The second schedule: starts at 10:00 and ends also at 10:00 am, it means no back-up heating in this time.

The third schedule: back-up heating function starts at 17:00 and ends at 22:00 pm. Within this time section, default switch-on temperature is 50°C; default switch-off temperature is 55°C.

The switch-on temperature adjustable range: 10 °C ~ (OFF-2 °C)

The switch-off temperature adjustable range: (ON+2 °C) ~ 80 °C

If you want to shut off one timing heating, then you can set the turning on time and turning off time with a same value (for example, the second time section without this function, then you can set turning on/off time is 10:00 ~ 10:00)

When time is outside of the preset schedule, back-up heating doesn't work automatically

even when the tank temperature drops to the switch –on temperature of heating.

Note:

- **When there is no sensor installed in the top part of tank (no T3 sensor), controller will take the signal of T2 (sensor in bottom of tank) automatically to control this function.**
- **The time in this controller is 24 hours mode, when you set schedule, the switch-off time of heating should be larger than switch-on time. For example: if you set the switch-on time of heating is at 17:00, but switch-off time of heating is 6:00, then this setting doesn't take effect, that means within this time section, heating function doesn't work. The correct set is like flowing: it should be divided into two time sections, one time section is from 17:00 to 23:59, the other time section is from 00:00 to 06:00.**

Setup steps: under standby status,

▶ Press “⌚ Heating” button to enter the timing setup interface, “tH 1o 04:00” shows on the screen, access the submenu of the switch-on time and temperature for the first schedule of heating function.



▶ Press “Set” button, hour “04” blinks on the screen, the switch-on time and temperature for the first schedule of heating function can be set.

▶ Press “▲ ▼” button to adjust hour of time.

▶ Press “Set” button again, minute “00” blinks on the screen.

▶ Press “▲ ▼” button to adjust minute of time.

▶ Press “Set” button, temperature “40°C” blinks on the screen.

▶ Press “▲ ▼” button, to set the switch-on temperature of heating.

▶ Then, press “Esc” to exit this submenu.

▶ Press “⌚ Heating” button, “tH 1F 05:00” shows on the screen, access the submenu of the switch-off time and temperature for the first schedule of heating function.

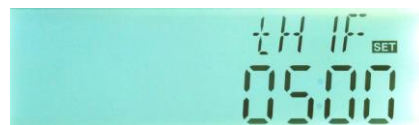

▶ Press “Set” button again, hour “05” blinks on the screen.

▶ Press “▲ ▼” button to adjust hour of time.

▶ Press “Set” button again, minute “00” blinks on the screen.

- ▶ Press “▲ ▼” button to adjust minute of time.
 - ▶ Repress “Set” button, temperature “45°C” blinks on the screen.
 - ▶ Press “▲ ▼” button, to set the switch-off temperature of heating.
 - ▶ Then, press “Esc” to exit this submenu; value of the parameters are saved automatically.
-

▶ Press “⌚ Heating” button to enter the timing setup interface, “tH 2o 10:00” shows on the screen, access the submenu of the switch-on time and temperature for the second schedule of heating function.

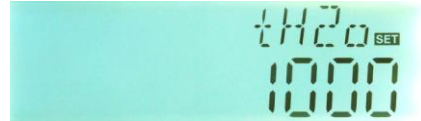

- ▶ Press “Set” button, hour “10” blinks on the screen; the switch-on time and temperature for the second schedule of heating function can be set.
 - ▶ Press “▲ ▼” button to adjust hour of time.
 - ▶ Repress “Set” button again, minute “00” blinks on the screen.
 - ▶ Press “▲ ▼” button to adjust minute of time.
 - ▶ Repress “Set” button, temperature “50°C” blinks on the screen.
 - ▶ Press “▲ ▼” button, to set the switch-on temperature of heating.
 - ▶ Then, press “Esc” to exit this submenu.
-

▶ Press “⌚ Heating” button, “tH 2F 10:00” shows on the screen, access the submenu of the switch-off time and temperature for the second schedule of heating function.

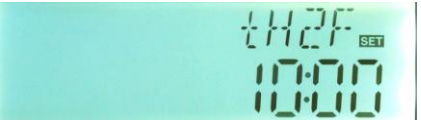

- ▶ Press “Set” button again, hour “10” blinks on the screen.
 - ▶ Press “▲ ▼” button to adjust hour of time.
 - ▶ Repress “Set” button again, minute “00” blinks on the screen.
 - ▶ Press “▲ ▼” button to adjust minute of time.
 - ▶ Repress “Set” button, temperature “55°C” blinks on the screen.
 - ▶ Press “▲ ▼” button, to set the switch-off temperature of heating.
 - ▶ Then, press “Esc” to exit this submenu; value of the parameters are saved automatically.
-

▶ Press “⌚ Heating” button to enter the timing setup interface, “tH 3o 17:00” shows on the screen, access the submenu of the switch-on time and temperature for the third schedule of heating function.

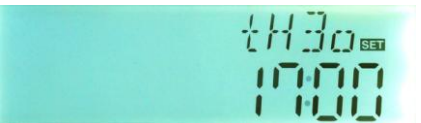

- ▶ Press “Set” button, hour “17” blinks on the screen; the switch-on time and temperature for the third schedule of heating function can be set.
- ▶ Press “▲ ▼” button to adjust hour of time.
- ▶ Repress “Set” button again, minute “00” blinks on the screen.
- ▶ Press “▲ ▼” button to adjust minute of time.
- ▶ Repress “Set” button, temperature “50°C” blinks on the screen.
- ▶ Press “▲ ▼” button, to set the switch-on temperature of heating.
- ▶ Then, press “Esc” to exit this submenu.

▶ Press “🕒 Heating” button, “tH 3F 22:00” shows on the screen, access the submenu of the switch-off time and temperature for the third schedule of heating function.

▶ Press “Set” button again, hour “22” blinks on the screen.

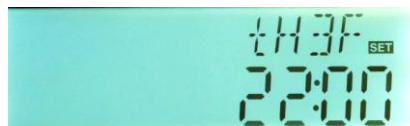

▶ Press “▲ ▼” button to adjust hour of time.

▶ Repress “Set” button again, minute “00” blinks on the screen.

▶ Press “▲ ▼” button to adjust minute of time.

▶ Repress “Set” button, temperature “55°C” blinks on the screen.

▶ Press “▲ ▼” button, to set the switch-off temperature of heating.

▶ Then, press “Esc” to exit this submenu or wait for 20 seconds to exit automatically; value of the parameters are saved automatically.

Note: when no gas or oil boiler is connected to solar system, electrical heater can be installed as back-up device, when electrical heater is in operation status, 🌡️ sign blinks on the screen.

If customer uses electrical heater as back-up, please according to the power of electrical heater to equip corresponding safety devices like contactor and breaker with this controller, we strongly recommend equipping with SR802 device with this controller, (SR802 detailed technical data see paragraph spare parts)

5.2 Energy save mode

Description:

At the time that user doesn't need electrical heater (e.g in Summer), if you trigger on this function, then timing heating function is overridden, but manual heating is effective

continuously, by this way you can save electricity.

▶ Press “Power Save” button, energy save sign shows on the screen, Energy save function is activated.

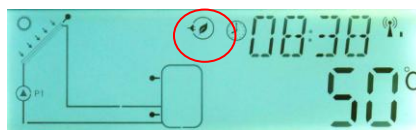

▶ Press “Power Save” button again to deactivate this function.

5.3 Temperature / time setting for DHW circulation pump

Description:

This controller can provide an output to control a DHW circulation pump, this function needs an extra circuit pump (connect with output P2) and an extra temperature sensor (connect with input T4) which mounted on the hot water return pipe. When the measured temperature is lower than the switch-on temperature of circulation pump, pump is triggered, until temperature rises up to the switch-off temperature, pump is stopped.

Note:

The running of DHW circulation pump can be controlled by temperature and time section. In below text how to set the time and temperature is described; it doesn't mean the function is activated. If you want to activate this function, you should access main menu FUN and select CIRC submenu and activate it. (See paragraph 6.5.2)

• Manually control DHW pump:

It is possible to manually trigger DHW pump P2 at any time, default running time is 3 minutes, after 3 minutes, pump P2 is stopped automatically.

Setup steps:

▶ Press “ON/OFF” button, “03” displays and blinks on the screen

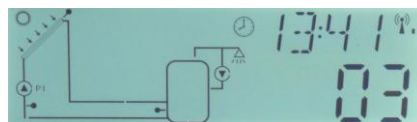

▶ Press “▲ ▼” button to adjust running time of pump P2, (default running time is 3 minutes, adjustable range is 1-60 minutes)

• Three time sections control DHW pump:

Within a time section, pump runs repeatedly as default: running for 3 minutes and

interval for 15 minutes.

- **Temperature and time control DHW pump:**

Within a time section, default condition: pump P2 runs when T4 drops to 40°C, pump P2 is stopped when T4 rises up to 45°C.

Startup condition of DHW temperature control: when tank temperature T3 is 1°C higher than the switch-off temperature of DHW circuit pump, DHW pump can be triggered.

Default time section:

- The first time section: start at 05:00, stop at 07:00
- The second time section: start at 11:00, stop at 13:00
- The third time section: start at 17:00, stop at 22:00
- If it is needed to close one time section, just set the start time and stop time at a same value (e.g. 10:00 start, 10:00 stop)

Note:

1)Temperature control mode is prior to time control mode

2)When pipe temperature sensor T4 is installed, the controller is automatically stop time control mode and transfer to the temperature control mode.

3)If install T4 sensor, in order to avoid measuring error, please be sure to install it at place minimum 1.5 meter far away to tank.

Setup steps: (time control mode):

Note: time setting steps for time and temperature mode is same like here described steps.

▶ Press “ ⊕ ” DHW” button, to access DHW time setting, “tC 1O 05:00” shows on the screen, now the start time of the first time section can be set.

▶ Press “Set” button, hour “05” blinks

▶ Press “▲ ▼” button, to adjust hour

▶ Press “Set” button, minute “00” blinks

▶ Press “▲ ▼” button, to adjust minute

▶ Press “Set” button, figure “03 MIN” blinks

▶ Press “▲ ▼” button, to adjust pump running time

▶ Press “Esc” button, to exit submenu

▶ Press “▲” button, “tC 1F 07:00” shows on the screen, now the stop time of the first



time section can be set.

- ▶ Press “Set” button, hour “07” blinks
- ▶ Press “▲ ▼” button, to adjust hour
- ▶ Press “Set” button, minute “00” blinks
- ▶ Press “▲ ▼” button, to adjust minute
- ▶ Press “Set” button, figure “15 MIN” blinks
- ▶ Press “▲ ▼” button, to adjust pump interval time
- ▶ Press “Esc” to exit this submenu or wait for 20 seconds to exit automatically; value of the parameter is saved automatically.

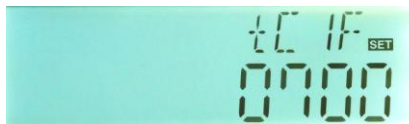

▶ Press “▲” button, “tC 2O 11:00” shows on the screen, now the start time of the second time section can be set.

- ▶ Press “Set” button, hour “11” blinks
- ▶ Press “▲ ▼” button, to adjust hour
- ▶ Press “Set” button, minute “00” blinks
- ▶ Press “▲ ▼” button, to adjust minute
- ▶ Press “Set” button, figure “03 MIN” blinks
- ▶ Press “▲ ▼” button, to adjust pump running time
- ▶ Press “Esc” button, to exit submenu
- ▶ Press “▲” button, “tC 2F 13:00” shows on the screen, now the stop time of the second time section can be set.

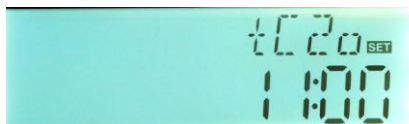

- ▶ Press “Set” button, hour “13” blinks
- ▶ Press “▲ ▼” button, to adjust hour
- ▶ Press “Set” button, minute “00” blinks
- ▶ Press “▲ ▼” button, to adjust minute
- ▶ Press “Set” button, figure “15 MIN” blinks
- ▶ Press “▲ ▼” button, to adjust pump interval time
- ▶ Press “Esc” to exit this submenu or wait for 20 seconds to exit automatically; value of the parameter is saved automatically.



▶ Press “▲” button, “tC 3O 17:00” shows on the screen, now the start time of the third time section can be set.

- ▶ Press “Set” button, hour “17” blinks
- ▶ Press “▲ ▼” button, to adjust hour

- ▶ Press “Set” button, minute “00” blinks
- ▶ Press “▲ ▼” button, to adjust minute
- ▶ Press “Set” button, figure “03 MIN” blinks
- ▶ Press “▲ ▼” button, to adjust pump running time
- ▶ Press “Esc” button, to exit submenu
- ▶ Press “▲” button, “tC 3F 22:00” shows on the screen, now the stop time of the third time section can be set.

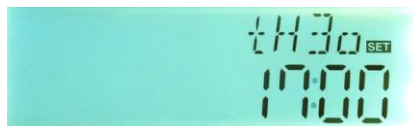

- ▶ Press “Set” button, hour “22” blinks
- ▶ Press “▲ ▼” button, to adjust hour
- ▶ Press “Set” button, minute “00” blinks
- ▶ Press “▲ ▼” button, to adjust minute
- ▶ Press “Set” button, figure “15 MIN” blinks
- ▶ Press “▲ ▼” button, to adjust pump interval time
- ▶ Press “Esc” to exit this submenu or wait for 20 seconds to exit automatically; value of the parameter is saved automatically.

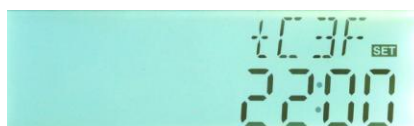

6. Functions operation and parameters setup (engineer grade)

6.1 Access main menu

Under standby, do like following steps to access main menu.

- ▶ Press “Set” button, “PWD 0000” appears on the screen, the left first figure blinks to ask for entering password, factory default set password is “0000” (press “SET” five times, to enter menu directly). If you have set password, then enter password like below steps.

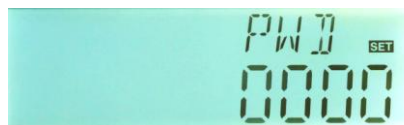

- ▶ Press “▲ ▼” button to enter first figure of password.
- ▶ Repress “Set” button, the second figure blinks
- ▶ Repress “▲ ▼” button, to enter second figure of password.
- ▶ Repeat press “Set” button, the third figure blinks
- ▶ Repress “▲ ▼” button, to enter third figure of password.
- ▶ Repeat press “Set” button, the forth figure blinks
- ▶ Repress “▲ ▼” button, to enter forth figure of password.
- ▶ Repress “Set” button, to access the main menu.
- ▶ Press “▲ ▼” button, select any menu you wanted.

▶ Press “Esc” button, you can exit main menu.

6.2 Access submenu

After access main menu and select a menu,

- ▶ Press “Set” button, to access the submenu option.
- ▶ Press “▲ ▼” button, roll the submenu and select one.
- ▶ Press “Set” button, to access the submenu setting.
- ▶ Press “▲ ▼” button, to adjust the parameter.
- ▶ Press “Esc” button, to exit the submenu.
- ▶ Reprress “Esc” button, to exit the main menu.

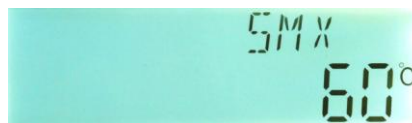

6.3 Temperature difference for solar circuit pump (DT O/DT F)

Description:

Solar circuit pump P1 is triggered by the temperature difference function, so long as the temperature difference between collector and storage reaches the switch-on DT, solar circuit pump is triggered. When the temperature difference between collector and storage drops to the switch-off DT, then solar pump is ceased.

For example: the switch-on DT is 8°C, switch-off DT is 4°C, if the temperature on the bottom part of storage is 20°C, then just when collector temperature rises up to 28°C, pump is triggered, and when collector temperature drops to 24°C, pump is ceased.

Note: the switch-on/off DT of 8°C and 4°C are standard system setting according to many years' experience, only in special application cases it may be changed, (e.g. far distance heat transferring), normally we recommend using default set. Switch-on and switch-off DT are alternating set. To avoid mistake the minimum difference between two temperature differences ($\Delta T_{on} - \Delta T_{off}$) is set as 2°C.

Setup switch-on temperature difference DT O

Under standby, following steps description in paragraph 6.1 to access main menu DT O

- ▶ Press “Set” button, to access settings program of main menu DT O, “DT O 08°C” shows on the screen, “08°C” blinks, the switch-on temperature difference can be set.

▶ Press “▲ ▼” button, to adjust the value of switch-on DT O, adjustable range (OFF+2 °C) ~20 °C, factory setting is 8 °C

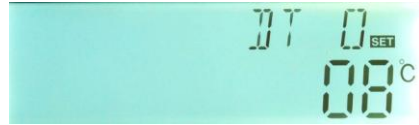

▶ Press “Esc” button to exit this setting, parameter is saved automatically.

Setup switch-off temperature difference DT F

Under standby, following steps description in paragraph 6.1 to access main menu DT F

▶ Press “Set” button, to access settings program of main menu DT F, “DT F 04 °C” shows on the screen, “04 °C” blinks, and the switch-off temperature difference can be set.

▶ Press “▲ ▼” button, to adjust the value of switch-off DT F, adjustable range 0°C ~ (ON-2 °C) , factory setting is 4 °C

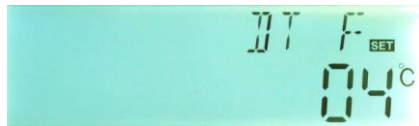

▶ Press “Esc” button to exit this setting, parameter is saved automatically.

▶ Press “Esc” to exit menu, or wait for 20 seconds to exit automatically, the setup parameters are saved automatically.

6.4 TEMP Temperature main menu

For solar system, the factory set parameters are for the best operation condition, which is fully integrated into the entire solar system. But these parameters can also be set individually to cater the special requirements, please carefully observe the operation data of system components after setting.

Note: Parameters that can be set rely on the system design, it means not all the parameters is suitable for all solar systems,

Following submenu can be access though TEMP main menu.

Tem. Code	Function of temperature	Adjustable range	Factor y set	Function exit tem.	Paragrap h
EMOF	Maximum switch-off temperature of collector	(ON+3°C)~200 °C	130 °C		6.4.1
EMON	Maximum switch-on temperature of collector	60 °C ~ (OFF-3 °C)	120 °C		6.4.2
CMX	Maximum limited temperature of collector (collector cooling function)	60 °C ~190 °C	110 °C	107 °C	6.4.3
CMN	Low temperature protection of collector	0 °C~90 °C	OFF		6.4.4
CFR	Frost protection temperature of collector	-10 °C~10 °C	OFF		6.4.5
SMX	Maximum temperature of tank	2 °C~95 °C	60 °C	58 °C	6.4.6
REC	Cooling temperature of tank		OFF		6.4.7
C - F	Switch between Celsius and Fahrenheit	°C ~ °F	°C		6.4.8

6.4.1 EMOF Maximum switch-off temperature of collector (for collector emergency close function)

Function description:

When collector temperature rises up to this maximum switch-off temperature (EM), collector emergency function is activated, solar circulation pump is stopped in order to avoid the damage of system's other components caused by high temperature. The adjustable range of EMOF temperature is (ON+3 °C~200 °C) , factory set is 130 °C. If the temperature of

collector rises up to EMOF limited temperature, solar circuit pump is ceased, but when collector temperature drops to the collector maximum switch-on temperature EMON (factory set is 120°C), solar circuit pump will be recovery, and collector emergency close function is deactivated.

Setup steps:

To access main menu TEMP, then select submenu EMOF, “EMOF 130°C” shows on the screen

▶ Press “Set” button, parameter “130 °C” blinks.

▶ Press “▲ ▼” button, to adjust this maximum

switch-off temperature, adjust range (ON+3 °C) ~200 °C, factory set is 130 °C

▶ Repress “Set” button to activate and deactivate this function, if deactivate the function, “EMOF - - -” shows on the screen.

▶ Press “Esc” button to exit menu or wait for 20 seconds to exit automatically, set parameters are saved automatically.



6.4.2 EMON Maximum switch-on temperature of collector (for collector emergency close function)

Setup steps:

To access main menu TEMP, then select submenu EMON, “EMON 120°C” shows on the screen

▶ Press “Set” button, parameter “120 °C” blinks.

▶ Press “▲ ▼” button, to adjust this maximum

switch-on temperature, adjust range 60 °C ~ (OF-3 °C), factory set is 120 °C

▶ Repress “Set” button to activate and deactivate this function, if deactivate the function, “EMON - - -” shows on the screen.

▶ Press “Esc” button to exit menu or wait for 20 seconds to exit automatically, set parameters are saved automatically.

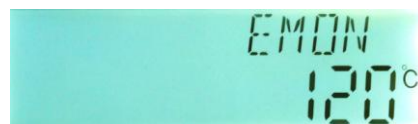

When these 2 signs of collector emergency close function blink on the screen, it indicates the function is activated, and tank temperature reaches up to its maximum limitation.

When only this sign of collector emergency close function blinks on the screen, it indicates the function is also activated, but temperature of tank doesn't reach to its

maximum limited temperature

6.4.3 CMX Maximum limited temperature of collector (collector cooling function)

Function description:

If hot water in tank isn't used for long time, then the capacity that solar system absorbs solar irradiation reduces, when tank temperature rises to its preset maximal temperature, solar circuit pump is ceased compulsively even the temperature difference is satisfied. then when more solar irradiation shines in, as a result collector temperature will rise continuously, temperature of collector maybe rise up to the evaporated temperature of heat fluid, this phenomenon names collector - overheat, it should be avoided. Through set the Maximum limited collector temperature (collector cooling function) it can delay the vaporization of the heat transfer fluid. Shortly before reaching the maximum temperature of the collector, the solar pump starts working to cool down the heat transfer fluid using the heat losses occurring in pipelines and storage cylinder.

When collector temperature rises up to its maximal temperature, solar pump will be triggered again even at the case that tank temperature is already to its maximal temperature. And solar pump works until the temperature of collector drops because of this reversed circulation or when tank temperature rises its emergency temperature (95°C).

When ☀ displays, and ⚠ blinks on the screen, it indicates that tank emergency temperature reaches, tank emergency stop function is activated, and tank temperature is $\geq 95^{\circ}\text{C}$

Setup steps:

To access main menu TEMP, then select submenu CMX, "CMX 110 °C" shows on the screen

▶ Press "Set" button, "110 °C" blinks.

▶ Press "▲ ▼" button to adjust collector limited maximum temperature , adjust range : (60 °C~190 °C) ,

Factory set is 110 °C

▶ Press "Set" button to activate and deactivate this function, if deactivate the function, "CMX - - -" shows on the screen.

▶ Press "Esc" button to exit menu or wait for 20 seconds to exit automatically, set parameters are saved automatically.



 CMX sign displays on the screen, it indicates that collector cooling function is activated.

6.4.4 CMN Low temperature protection of collector

Description:

When the actual temperature of collector is below the preset CMN temperature, solar circuit pump is ceased, even when the temperature difference between collector and storage exceeds switch-on temperature difference, solar pump doesn't work yet. When the temperature of collector is 3°C higher than the preset CMN temperature, solar circuit pump is standby to work, controller exits this program.

Setup steps:

To access main menu TEMP, then select submenu CMN, "CMN - - -" shows on the screen, default set is OFF.

▶ Press "Set" button, default off sign "- - -" blinks on the screen.



▶ Repress "Set" button to activate and deactivate this function.

▶ Press "▲ ▼" button to adjust the low protection temperature of collector CMN, adjustable range (00°C ~90°C), after activate the function, factory set is 10°C

▶ Press "Esc" button to exit the menu or wait for 20 seconds to exit automatically, parameters are saved automatically.

 CMN sign displays on the screen, it indicates that this function is activated.

6.4.5 CFR frost protection temperature of collector

Description:

In winter when the temperature of collector is below the preset frost protection temperature (factory set is 4°C), solar circuit pump is triggered to transfer hot water from tank to collector and to heat collector by this reversed circuit. And when tank temperature (T2) drops to 6°C, electrical heater is triggered automatically and it keeps running until tank temperature T2 rises up to 21°C or it is stopped when program of CFR is exited. When collector temperature rises up to 7°C, solar circuit pump is ceased, program of CFR exits

automatically.

This function is used in system, which uses water as heat transfer liquid, to avoid the freezing of solar heat transfer fluid.

Setup steps:

To access main menu TEMP, then select submenu CFR, "CFR ----" shows on the screen, default set is off.

- ▶ Press "Set" button, default off "- - -" blinks.
- ▶ Repress "Set" button to activate or deactivate this function



- ▶ Press "▲ ▼" button to adjust the temperature of frost protection function, adjustable range is $(-10^{\circ}\text{C}\sim 10^{\circ}\text{C})$, after function is activated, default set is 4°C

- ▶ Press "Esc" button to exit the menu or wait for 20 seconds to exit automatically, parameters are saved automatically.



CFR sign shows on the screen, it indicates that this function is activated.

Note: this function is only available in special solar system which using un-anti-freezing liquid; this kind of system is only suitable in area where the ambient temperature is near to 0°C only for a few days. If safety requirement is very high, then anti-freezing liquid is necessary, we suggest using suitable anti-freezing liquid to avoid frost problem.

6.4.6 SMX Maximum temperature of tank

Description:

When the DT between collector T1 and tank T2 caters the switch-on DT of circulation, solar pump is triggered, but in order to avoid the high temperature inside tank, controller will check whether the temperature (T3) of the top part of tank is higher than the maximum temperature of tank, when T3 is higher than the preset maximum tank temperature SMX, solar pump is ceased even at the case that DT caters condition. When tank temperature drops and is 2°C below the SMX temperature, solar pump restarts when DT caters condition.

Setup steps:

To access main menu TEMP, then select submenu SMX, “SMX 60 °C” shows on the screen.

- ▶ Press “Set” button, parameter “60 °C” blinks
- ▶ Press “▲ ▼” button to adjust the value of maximum temperature of tank, adjustable range is (2 °C~95 °C) , default set is 60 °C

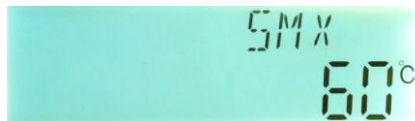

- ▶ Repress “Set” button to activate and deactivate this function, if function deactivated, “SMX - - -” displays on the screen.
- ▶ Press “Esc” button to exit the menu or wait for 20 seconds to exit automatically, parameters are saved automatically.



SMX sign shows on the screen, it indicates that this function is activated.

6.4.7 REC Cooling temperature of tank

Description:

If storage temperature rises up to its maximum temperature, and at the same time, collector temperature is 5°C lower than storage temperature, then solar pump can be triggered, through this reversed circulation, storage temperature is reduced by heat loss occurs in collector, solar pump keeps in working until storage temperature drops below its maximum temperature.

Setup steps:

To access main menu TEMP, then select submenu REC, “REC OFF” shows on the screen, default set is off.

- ▶ Press “Set” button, parameter “OFF” blinks on screen
- ▶ Repress “Set” button to activate or deactivate this function; after function activated, factory set is “REC ON”

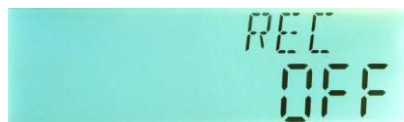

- ▶ Press “Esc” button to exit the menu or wait for 20 seconds to exit automatically, parameters are saved automatically.



REC sign displays on the screen, it indicates that this function is activated.

6.4.8 C_F Switch between Celsius and Fahrenheit

Setup steps:

To access main menu TEMP, then select submenu C_F, "C_F °C" shows on the screen,

▶ Press "Set" button, displayed parameter blinks on the screen

▶ Press "▲" button, to select Celsius or Fahrenheit temperature unit, default set is °C

▶ Press "Esc" button to exit the menu or wait for 20 seconds to exit automatically, parameters are saved automatically.



6.5 FUN Auxiliary functions

The auxiliary functions of this controller can be set under menu "FUN"; it is possible to activate several auxiliary functions at the same time.

Note:

Sometimes, the selected function needs controller to have an extra input to connect a temperature sensor or an extra output to control a pump or electromagnetic valve.

Under main menu "FUN", some submenu functions maybe deactivated, so the displayed contents for below mentioned submenu functions maybe different.

For example:

If you deactivate thermal energy measuring function (OHQM), then FMAX, MEDT, MED% submenu will not be displayed, only when you activate OHQM function, they can be displayed under submenu (see menu structure in paragraph 4.2).

Following submenu can be access though FUN main menu.

Function code	Function description	Paragraph
DVWG	Anti legionnaires' function	6.5.1
CIRC	DHW circulation pump on/off	6.5.2
COOL	Tank cooling function	6.5.3
BYPA	Bypass (high temperature)	6.5.4

6.5.1 DVWG Anti legionnaires' function

Description:

In order to avoid occurring bacteria in water tank when the temperature of tank is lower for a long time, controller will check the temperature of tank every 7 days in a period automatically, if the temperature of tank is never over 70°C during this period, then at the factory default time of 01:00 on Sunday, auxiliary heating system is triggered automatically to heat water until its temperature rises up to 70°C (this is factory default set, impossible to reset) , bacteria is killed by high temperature, thereafter function is deactivated.

Setup steps:

To select submenu DVWG, “DVWG OFF” shows on the screen. Default set is “OFF”.

▶ Press “Set” button, parameter “OFF” blinks on the screen.

▶ Press “▲ ▼” button and “DVWG ON” shows on the screen, then to activate this function.

▶ Press “Esc” button to exit the menu or wait for 20 seconds to exit automatically, parameters are saved automatically.

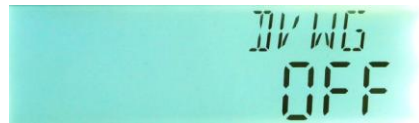

6.5.2 CIRC DHW circulation pump on/off

Setup steps:

To select submenu CIRC, “CIRC OFF” shows on the screen. Default set is “OFF”.

▶ Press “Set” button, parameter “OFF” blinks on the screen.

▶ Press “▲ ▼” button and “CIRC ON” shows on the screen, then to activate this function.

▶ Press “Esc” button to exit the menu or wait for 20 seconds to exit automatically, parameters are saved automatically.



6.5.3 COOL Tank cooling function

Description:

Tank cooling function is independent from solar system, it is used to transfer the extra thermal energy from tank to other heat release device, and as a result, tank temperature can be kept at a constant value. So for this function, an extra pump should be installed in

the system, and it is controlled by output R1.

For example:

We set the temperature of 80°C is the condition to run the cooling function, then when tank temperature T3 rises up to 80°C, cooling function is activated automatically, pump R1 starts to work, when tank temperature drops to 77°C, the pump P1 is stopped.

Setup steps:

To access submenu COOL, “COOL - - -” displays on the screen.

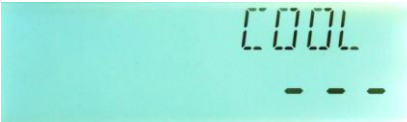

▶ Press “Set” button, parameter “- - -” blinks on the screen, default set is OFF.

▶ Reprress “Set” button to activate or deactivate this function; after function activated, “COOL 80°C” displays on the screen and 80°C blinks,

▶ Press “▲ ▼” button to adjust temperature, adjustable range (5 °C ~95°C)

▶ Press “Esc” button to exit the menu or wait for 20 seconds to exit automatically, parameters are saved automatically.

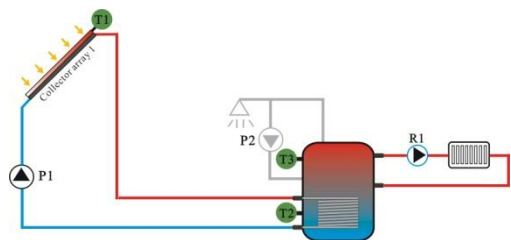

Example (only for reference)

Note:Both functions of “COOL” and “BYPR” use same output R1,so only one (“COOL” or “BYPR”)available at the same time.

6.5.4BYPR Bypass function (high temperature)

Description:

In the case that tank temperature rises up to its maximum temperature (SMX), and if the collector temperature T1 rises up to BYPR temperature, then solar pump can be triggered, at the same time, electromagnetic T-valve R1 is triggered also to release extra heat by radiator or pipe. Collector temperature drops and when it is 10°C below the BYPR temperature or when tank temperature T3 is below its maximum tank temperature (SMX), then P1 and R1 are stopped at the same time.

Setup steps:

To access submenu BYPR, “BYPR - - -” displays on the screen.

▶ Press “Set” button, parameter “- - -” blinks on the screen, default set is OFF.

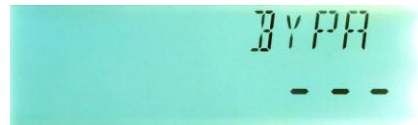

▶ Re-press “Set” button to activate or deactivate this function; after function activated, “BYPR 80°C” displays on the screen and 80°C blinks.

▶ Press “▲ ▼” button to adjust temperature, adjustable range (5 °C ~120°C)

▶ Press “Esc” button to exit the menu or wait for 20 seconds to exit automatically, parameters are saved automatically.

Application example (only for reference)

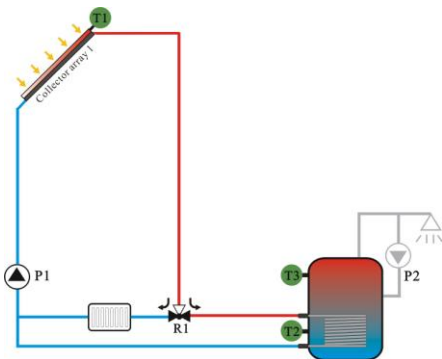

Release heat by radiator

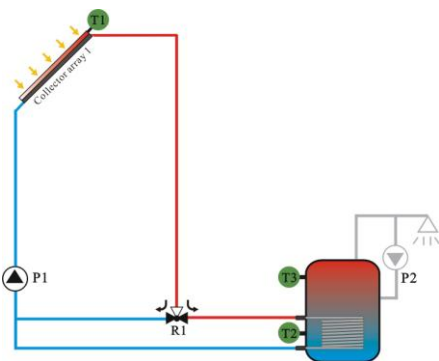

Release heat by pipe

Note: Both functions of “COOL” and “BYPR” use same output R1, so only one (“COOL” or “BYPR”) available at the same time.

6.6 COMM Communication function menu

Note:

1) The MAC, FREQ of displays which are matched with this controller should all be same.

2) ID, MAC and RSSI are not adjustable in this controller, these submenu are used only for checking the value used in this controller.

6.6.1 ID Address

Select COMM communication menu, “COMM” shows on the screen.

▶ Press “Set” button, to check ID address of this



display, "ID 01" shows on the screen.

6.6.2 MAC Network address

Select MAC network address submenu, "MAC 685" shows on the screen.



6.6.3 FREQ Communication frequency

Select FREQ submenu, "FREQ 433" shows on the screen.

▶ Press "Set" button, parameter "433" blinks on the screen; factory set is "433". Adjustable frequency is 431-435 MHz.

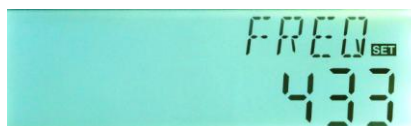

▶ Press "▲ ▼" button, to adjust parameter

▶ Press "Esc" button to confirm the parameter you set.

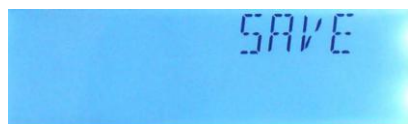

▶ Press "▲" 2 times, "SAVE" blinks on the screen.

▶ Press "Set" button, "WAIT- - -" shows on the screen, waiting for 10 seconds, "SAVE" blinks, and

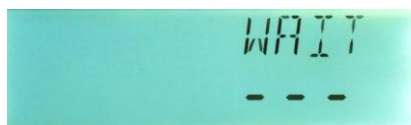

system recover to normal operation status in 20 seconds automatically, then new communication frequency is successful.

(if after setting the new frequency, and "WAIT - -" displays on the screen, but matching with controller is unsuccessful, then error code "ERR" shows on the screen, you need to revise the communication frequency).

6.6.4 RSSI Signal intensity

Select RSSI signal intensity submenu, "RSSI 31" shows on the screen.



6.7 HND Manual control

When using this controller first time or when debugging this controller, outputs of this controller(P1, P2,R1,H1) can be triggered manually with "On, OFF" control.

Setup steps:

To access main menu HND,

▶ Press “Set” button, “HND1 off” displays on the screen,

P1 output manually set

▶ Repress “Set” button, “HND1 on” displays on the

screen, P1 output is switched-on

▶ Repress “Set” again, “HND1 off” displays, P1 output is switched-off

▶ Press “Esc” to exit setup P1.

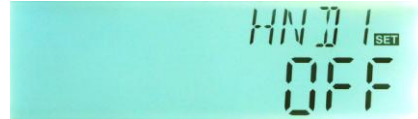

▶ Press “▲” button, “HND2 off” displays on the screen,

P2 output manually set

▶ Press “Set” button, “HND2 on” displays on the screen,

P2 output is switched-on

▶ Repress “Set” again, “HND2 off” displays, P2 output is switched-off

▶ Press “Esc” to exit setup P2.

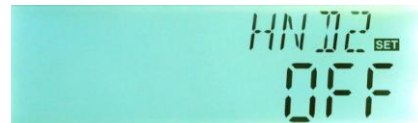

▶ Press “▲” button, “HND3 off” displays on the screen,

R1 output manually set

▶ Press “Set” button, “HND3 on” displays on the screen,

R1 output is switched-on

▶ Repress “Set” again, “HND3 off” displays, R1 output is switched-off

▶ Press “Esc” to exit setup R1.



▶ Press “▲” button, “HND4 off” displays on the screen, H1 output manually set

▶ Press “Set” button, “HND4 on” displays on the screen,

H1 output is switched-on

▶ Repress “Set” again, “HND4 off” displays, H1 output is switched-off

▶ Press “Esc” to exit setup H1.

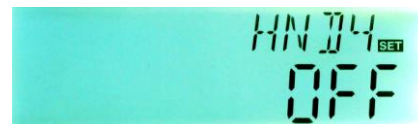

Note: when manual mode is activated, (HND) sign displays on the screen, after 15 minutes all outputs are switched-off automatically, controller exits manual mode.

6.8 PASS Password set

Setup steps:

To access main menu PASS,

▶ Press “Set” button, “PWDC 0000” appears, the left figure blinks, ask for entering current password (factory set is “0000”)



▶ Press “ ▲ ▼ ”button to enter the first figure

▶ Repress “Set” button, the second figure blinks



▶ Press “ ▲ ▼ ”button to enter the second figure

▶ Repress “Set” button, the third figure blinks

▶ Press“ ▲ ▼ ” button to enter the third figure



▶ Repress “Set” button, the fourth figure blinks

▶ Press“ ▲ ▼ ” button to enter the fourth figure

▶ Press “Set” button, “PWDC 0000” shows on the screen, ask for entering a new password, doing like above to enter the new password

▶ Press “Set” button, “PWDC 0000” shows on the screen, ask for reentering the new password, doing like above to reenter the new password, “PWOK” shows on the screen to indicate reentering password successfully.

▶ Press “Esc” button to exit set program or wait for 20 seconds to exit automatically.



Warning!

If the password is forgot, it is not possible to recover, but you can recover the password to factory set, then you can reedit a password like above descript steps, doing like following to recover to factory set.

▶ Open the cover of display's button panel

▶ Press “ON/OFF” and hold it down, and press “Reset”.

Buzzer makes “du----” 3 times, then release “ON/OFF” button. Controller recovers to factory set(factory set password is 0000), a new password can be reset now.

6.9 LOAD Recovery to factory set

Setup steps:

To access main menu LOAD,

▶ Press “Set” button, “YES” displays on the screen.

▶ Hold down “Set” button, buzzer makes “du-----” 3 times, then release “Set” button and wait for display recovery to initial interface, that means controller recovers to factory set, new parameters can be reset now.

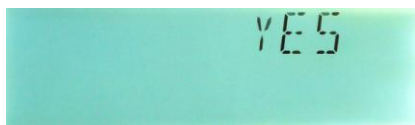

▶ Press “Esc” button to exit set program or wait for 20 seconds to exit automatically.

6.10 “ON/OFF” Controller switch on/off button

Under standby status,

▶ Press “ON/OFF” button for 2 seconds, controller enters close status, “OFF” displays on the screen (and left LED indicator light blinks 1 time every 2 seconds).



▶ Press “ON/OFF” button, Controller recovers to open status.

6.11 Holiday function

Description:

This function activates in night, solar liquid will flow from storage tank to collector to cool the tank, and therefore to prevent overheating problem of the solar system in the case that tank is already heated completely. The function is activated at night between 10 pm and 6 am, when the temperature of collector is 8 °C below the tank temperature (T2), solar circuit pump starts to work until the temperature of collector is 2 °C below the tank temperature, and then solar circuit pump is ceased.

Activate this function if:

- You intend to be absent for an extended period (holiday)
- No hot water is required for an extended period.
- The function is deactivated when the temperature on bottom of tank is below 35 °C.
- When the holiday pass by, holiday function is deactivated automatically.

Activate/ deactivate this function:

▶ Press “Holiday” button for 3 seconds, sign of holiday function  displays on the screen, holiday day number “07” blinks on the screen.

▶ Press “▲ ▼” button to adjust the holiday period, adjustable range is 1-60 days.

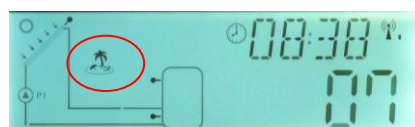

▶ Press “Holiday” button, holiday sign  disappears, holiday function is deactivated.

6.12 Manual heating

Description:



Electrical heater, gas or oil boiler can be as back-up devices in a solar system, this controller can achieve constant temperature controlling, when temperature of top part tank (T3) is 3 °C below the preset switch-on temperature, back-up heating will be triggered. When the temperature on the top part tank (T3) rises up to the preset temperature, then heating is ceased.

Conditions for triggering manual heating function: the preset switch-on temperature of this function should be 3 °C higher than the tank temperature.

Activate/deactivate the function:

▶ Press “Manual  ” button, temperature “60 °C” blinks on the screen.

▶ Press “▲ ▼” button to adjust switch-on temperature, adjustable range 10 °C~80 °C, factory set is 60 °C.

After 20 seconds, this function is activated, signal  displays on the screen, and heating sign  blinks also.

▶ Press “Manual  ” button again, to switch-off manual heating function.

Note: manual heating can only heat tank one time, after manual heating is triggered, when temperature of tank rises up to the preset temperature, manual heating ceases, and manual heating function will be deactivated automatically, if customer wants to heat again, you need redo according to above steps.

6.13 Temperature query function

Under standby status,

▶ Press “▲ ▼” button , you can check the value of temperature sensors T1~ T4, signal intensity(RSSI), time and date.

When checking temperature, T1 – T4 displays one by one, corresponding sensor signal  blinks.

▶ Press “Esc” button, current time and tank temperature display on the screen.

Note: T4 temperature can only be checked after triggering the function of CIRC DHW circulation pump.

7. Protection function

7.1. Memory protection



In case power failure occurs, controller keeps the parameter settings unchanged.

7.2 Screen protection











When no any press on button for 3 minutes, screen protection is activated automatically, and then LED background lamp is switched-off. Through press any button to light LED lamp again.

8. Trouble shooting

8.1 Trouble protection



a. When there is a break or short circuit between the connection of temperature sensors, controller switches off the corresponding functions and no more output signals are given, LED indicator lamp  blinks, at the same time error sign  shows on the screen. If controller does not work correctly, please check following points.

► Press “▲ ▼” button to check error code, warning sign  blinks on the LCD screen

Display LED lamp	LCD shows Error message	CODE Meaning	Cause of error	Error rectification
 blinks	 T1 ---	T1 sensor problem	Sensor wiring short or open	Check resistance value or replace
 blinks	 T2 ---	T2 sensor problem	Sensor wiring short or open	Check resistance value or replace
 blinks	 T4 ---	T4 sensor problem	Sensor wiring short or open	Check resistance value or replace
		DHW circuit pump temperature control is activated.	T4 sensor not connected	Connect T4 sensor, deactivate functions(CIRC)
 blinks	 E0	Communication error	No communication between controller and display	Code match again
 blinks	 E1	Data synchronize error	Display and controller is not synchronized	Press display reset button to recover again
			Distance to the controller may be too far	Remount the display in a suitable place

8.2 Trouble checking

The controller is a qualified product, which is conceived for years of continuous trouble-free operation. If a problem occurs, the most of causes is from the peripheral components but no relation with controller itself. The following description of some well-known problems should help the installer and operator to isolate the problem, so that the system can be put into operation as quickly as possible and to avoid unnecessary costs. Of course, not all possible problems can be listed here. However, most of the normal problems encountered with the controller can be found in the list below, only return the controller to seller when you are absolutely sure that none of the problems listed below is responsible for the fault.

Symptoms	Secondary symptoms	Possible cause	Procedure
Controller does not appear any functions at all	Display shows nothing, no display illumination	Controller power supply is interrupted or program is out of work	Check the controller power cable and fuse
The solar pump doesn't operate, despite the fact that switch-on conditions are satisfied	The pump symbol on the display blinks	Pump power supply is interrupted	Check the pump power cable
Solar circuit pump doesn't operate	The pump symbol in the display doesn't blink.  Lighting  blinks	The maximum storage tank temperature (SMX) has been reached The maximum collector temperature (EM) has been reached.	No fault
	 T1 --- Error message displays on the screen	Sensor fault (short circuit or open circuit)	Check values of every connected sensor; replace all defective sensors and /or cabling.
The solar pumps operated, despite the fact that the switch-on conditions are not satisfied	The pump symbol on the display blinks.	Holiday function or Frost protection function or tank re-cooling function is activated.	No problem, it is normal. If necessary to deactivate the corresponding functions.



Warning! Remove the device from the mains supply before opening the case

A potentially defective sensor can be checked using an ohmmeter. To do this, the

sensor must be disconnected, its resistance measured, and the value compared with the figure in the table below, small deviation ($\pm 1\%$) is acceptable.

PT1000 resistance value

$^{\circ}\text{C}$	0	10	20	30	40	50	60	70	80	90	100
Ω	1000	1039	1077	1116	1155	1194	1232	1270	1309	1347	1385

NTC 10K B=3950 resistance value

$^{\circ}\text{C}$	0	10	20	30	40	50	60	70	80	90	100
Ω	33620	20174	12535	8037	5301	3588	2486	1759	1270	933	697

9. Quality Guarantee

Manufacturer provides following quality responsibilities to end-users: within the period of quality responsibilities, manufacturer will exclude the failure caused by production and material selection. A correct installation will not lead to failure. When a user takes incorrect handling way, incorrect installation, improper or crud handling, wrong connection of sensor in system and incorrect operation, the quality responsibility is invalid for them.

The quality warranty expires within 24 months after the date of purchasing the controller.

10. Technical specification



Parameter	Value
Size of display	130mm×130mm×25mm
Size of controller	200mm×140mm×43mm
Power supply	AC100~240V, 50~60Hz
Power consumption	< 1.8W
Measure accurate	±2°C
Measure scope of collector sensor	-10~220°C
Measure scope of tank sensor	0~110°C
Pump can be controlled	3 pumps, pump power ≤ 300W
Electrical heater can be controlled	1 heater, heater power ≤ 1500W
Signal inputs	Collector : 1* PT1000 , ≤ 500°C (Silicon cable ≤ 280°C) Tank or pipe: 3 * NTC10K, B=3950, ≤135 °C (PVC cable ≤105 °C)
Signal outputs	3 outputs, to control circuit pump or electromagnetic valve, 1 output for control electrical heater
Operation frequency	430-450MHz , free to use without ISM admission certificate
Emission power:	≤20dBm
Communication distance in open field	Up to 600 meter (baud rate 4.8Kbps/9.6Kbps)
Ambient temperature	-10~50 °C
Water proof grade	IP40



11. Package list

Products name	Quantity
Display	1 piece
Controller	1 piece
User manual	1 piece
PT1000 sensor ($\phi 6*50\text{mm}$, cable length 1.5m)	1 piece
NTC10K sensor ($\phi 6*50\text{mm}$, cable length 3m)	2pieces
Mounting accessories (expansion screw, clamps)	1 piece
Power cable	1 piece

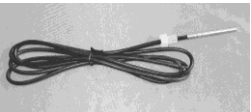
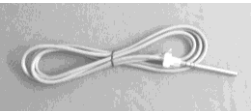
12. Device matched to this controller

Products listed in below table are useful accessories for this controller; it is not included in the standard package, if you need, please order it separately.

Products name	Specification	Products picture
A01 High accurate Pt1000 sensor for collector	PT1000, $\phi 6*50\text{mm}$	
A02 High accurate sensor for tank and pipe	NTC10K, B=3950, $\phi 6*50\text{mm}$	
A05 304 stainless steel thermowell	304 stainless steel with thread 1/2' OT, Size: $\phi 8*200$	

<p>SR528Q Wireless display</p>	<p>Operation frequency: 430-450MHz frequency, free to use without ISM admission certificate. Emission power: ≤ 20dBm Modulation mode: FSK modulation Communication distance in open field: up to 600 meter, (baud rate 4.8Kbps/9.6Kbps)</p>	
<p>SR802 Unit for high power electrical heater</p>	<p>Dimension: 100mmx100mmx65mm Power supply: AC180V ~ 264V, 50/60Hz Suitable power: ≤ 4000W Available ambient temperature: -10 ~ 50°C Waterproof grade: IP43</p>	

SR802 connection diagram:

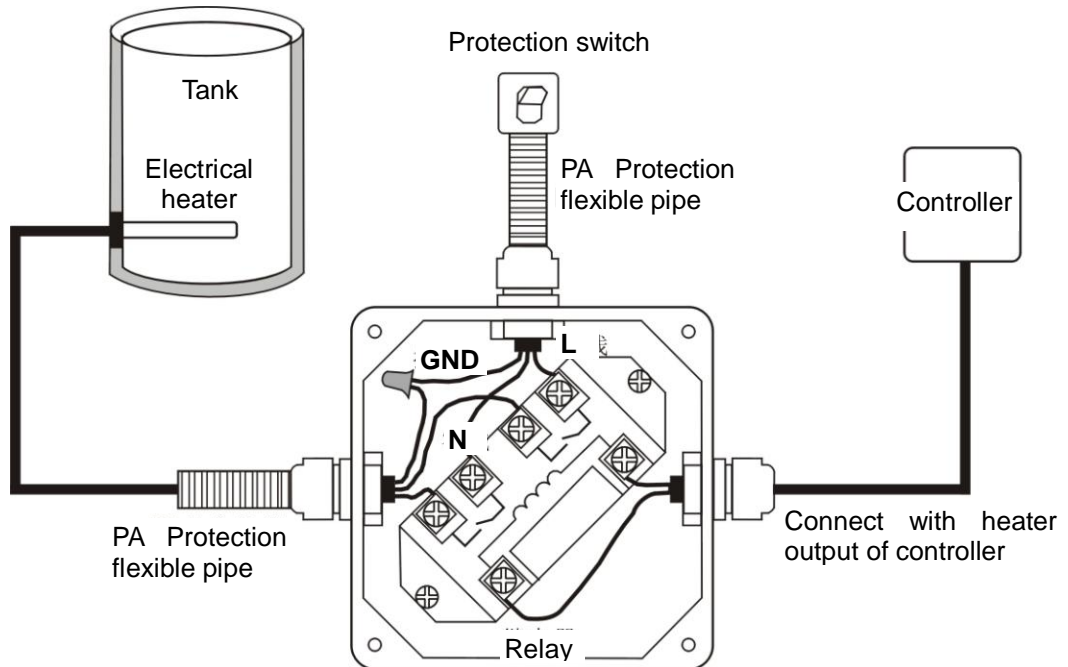

Note: Switch-off power, and perform by profession installer.